



BERG Technics

ACCESSORIESCATALOGUE

EXTRACTION / FILTER / POLLUTION CONTROL // TECHNOLOGY

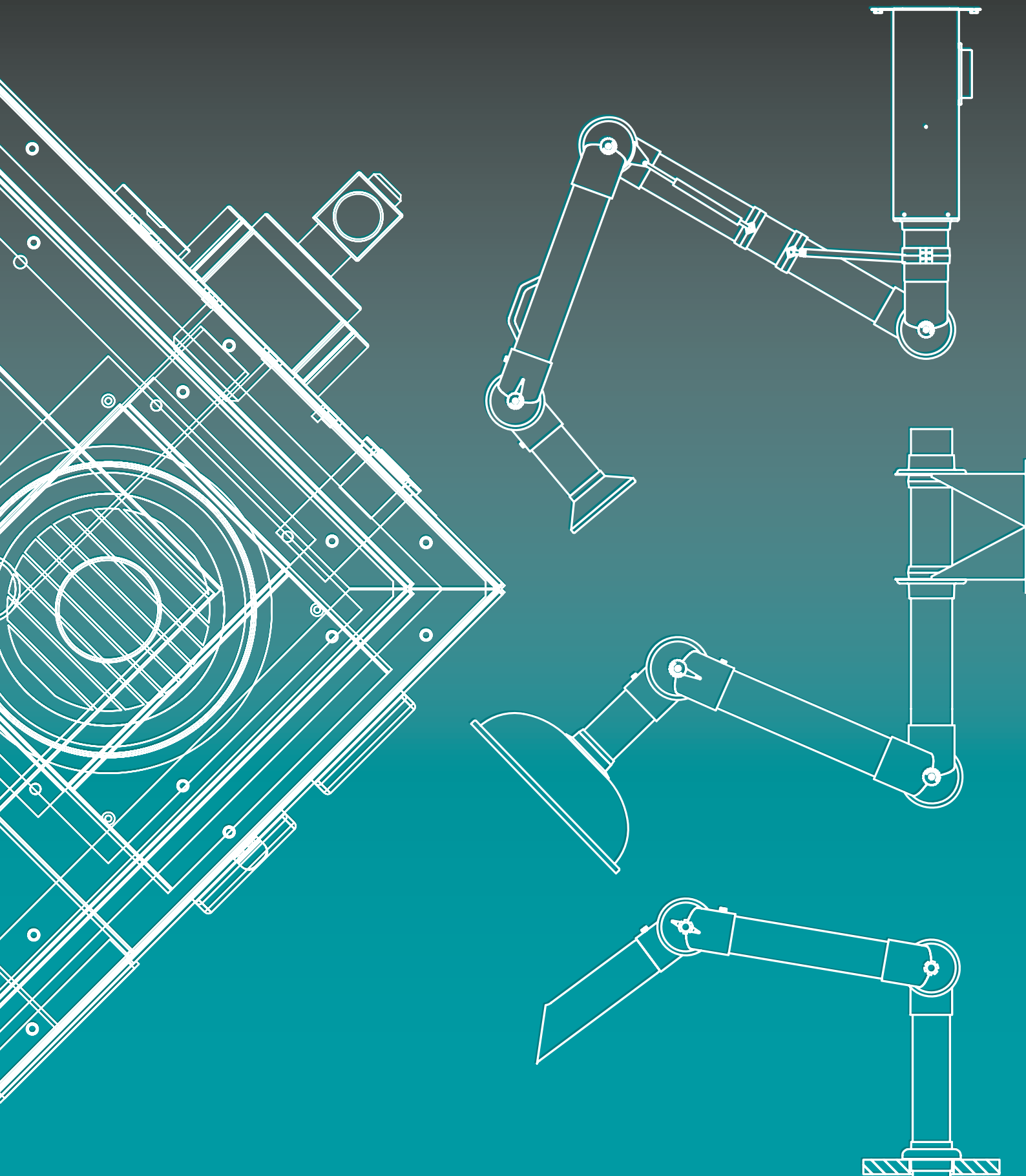

TABLE OF CONTENTS:

Accessories for Alsident SYSTEM	3
SYSTEM 50	5
Order data SYSTEM 50-AL	6
Order data SYSTEM 50-AL-FLEX	7
Collection elements SYSTEM 50-AL	8
Holder and base box SYSTEM 50-AL	12
Further accessories SYSTEM 50-AL	14
Order data SYSTEM 50-AS	16
Order data SYSTEM 50-AS-FLEX	17
Collection elements SYSTEM 50-AS	18
Holder and base box SYSTEM 50-AS	21
Further accessories SYSTEM 50-AS	23
SYSTEM 63	25
Order data SYSTEM 63-CB	26
Collection elements SYSTEM 63-CB	27
Holder and base box SYSTEM 63-CB	30
Further accessories SYSTEM 63-CB	32
SYSTEM 75	35
Order data SYSTEM 75-AL	36
Collection elements SYSTEM 75-AL	37
Holder and base box SYSTEM 75-AL	40
Further accessories SYSTEM 75-AL	42
Order data SYSTEM 75-AS	44
Collection elements SYSTEM 75-AS	45
Holder and base box SYSTEM 75-AS	47
Further accessories SYSTEM 75-AS	49
Order data SYSTEM 75-CB	50
Collection elements SYSTEM 75-CB	51
Holder and base box SYSTEM 75-CB	53
Further accessories SYSTEM 75-CB	55
SYSTEM 100	57
Order data SYSTEM 100-AL	58
Collection elements SYSTEM 100-AL	60
Holder and base box SYSTEM 100-AL	63
Further accessories SYSTEM 100-AL	65
Order data SYSTEM 100-AS	66
Collection elements SYSTEM 100-AS	68
Holder and base box SYSTEM 100-AS	70
Further accessories SYSTEM 100-AS	71
Order data SYSTEM 100-CB	72
Collection elements SYSTEM 100-CB	74
Holder and base box SYSTEM 100-CB	76
Further accessories SYSTEM 100-CB	78
SYSTEM 25	81
Order data SYSTEM 25 TYPE 1	82
Order data SYSTEM 25 TYPE 2	83
Order data SYSTEM 25 TYPE 3	84
Special suction arms SYSTEM 160	86
Hoses	89
Pipes and pipe connection components	93
Accessories pipes and pipe connection components	102
Slide valves	103
Pre-separator	104
Fans	106
Extraction bench, extraction panel	109
Remote controls	110
Miscellaneous	111

ACCESSORIES FOR ALSIDENT SYSTEM

SUCTION ARMS AND HOODS OF THE ALSIDENT SYSTEM

TBH GmbH has been distributing Alsident's products in Germany for many years and offers the full range of products in the field of source extraction.

Alsident System A/S is the world's leading manufacturer of source extraction for more than 30 sectors. The wide range of products corresponds to various requirements and has been adapted to the specific areas of application.

AREA OF APPLICATION

The suction arms and hoods are used to collect pollutants directly, right at their point of origin (source extraction). Their high degree of flexibility allows them to be adapted to each individual application. Please contact your TBH sales team regarding your specific application.

Alsident System provides you with the right product according to the specific substances which arise and are extracted from your process.

APPLICATION AIDS

TECHNICAL DESIGN	SYSTEM				
	25	50	63	75	100
Standard application: PP joints/aluminium pipes		■		■	■
ESD/ATEX application: PP joints/aluminium pipes (System50), PP joints/PP pipes conductive with earth connection		■		■	■
Aggressive substances: PP joints/PP pipes (chemically resistant)			■	■	■
Extraction cabinet for extensive extraction	■				

Give us a call. We will be happy to assist you with your selection.

ALSIDENT SUCTION ARMS

Source extraction during the working process, right at the contaminant's point of origin, is the most efficient way of collecting hazardous substances. Alsident System's suction arms are constructed to be self-supporting, whereby the threaded pins and springs are located within the arm. This makes the suction arm very easy to handle and position at the contaminant's point of origin. It is also possible to install the suction arms in a TBH extraction and filtration unit. The arm can be easily assembled and disassembled without tools.

All of Alsident System's suction arms are manufactured from high-quality materials which makes maintenance easy and ensures a long service life. This is why all plastic parts are made of shock-proof polypropylene (PP), all aluminium parts are anodised, all accessories parts are powder-coated, threaded pins and springs in the suction arm are made of acid-proof, stainless steel and why all of the O-rings are designed to be maintenance-free.

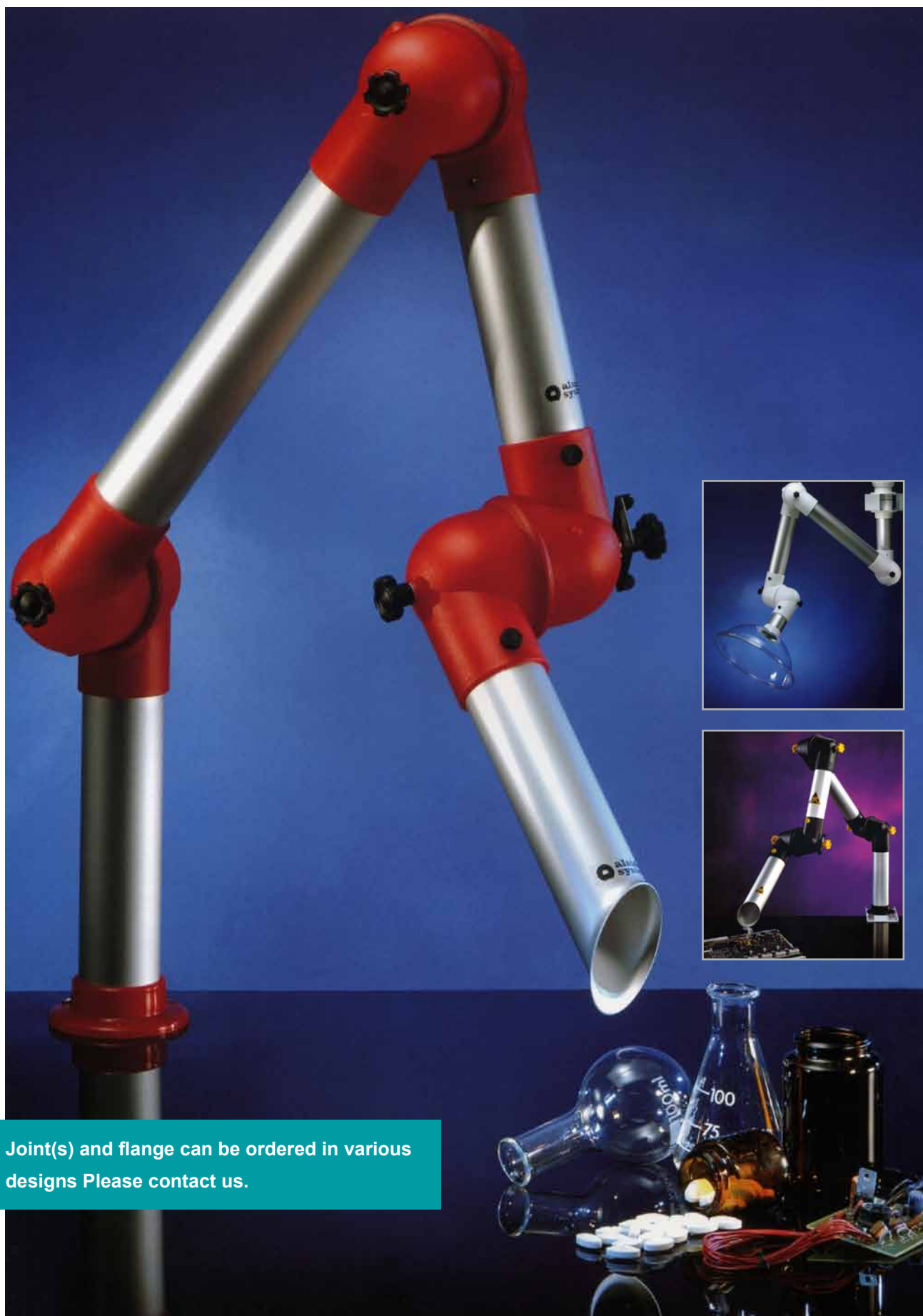

Joint(s) and flange can be ordered in various designs Please contact us.

ALSIDENT® SYSTEM 50 is suited for air volumes between 45-85 m³/h (25-50 CFM).

ALSIDENT® SYSTEM 50 is very applicable in trades with small pollutants, such as the electronics industry, laboratories, dental clinics, laser technique, classrooms at schools, hairdressing schools and hairdressing saloons, nail studios, decorator workshops and goldsmith's workshops.

Adjusted to the work conditions

The ALSIDENT® SYSTEM 50 suction arms are quickly mounted with standard brackets for table, wall or ceiling. The ALSIDENT® SYSTEM 50 Flexible extraction arm is ready for mounting on a table.

The standard ALSIDENT® SYSTEM 50 is available in various types that are complementary to each other with reaches up to 1.660 mm (65.35"). Therefore it is possible to choose an extraction arm applicable for each work situation.

The suction arms are fitted with throttle valves to regulate the volume flow.

Aluminium (AL) – for most applications

ALSIDENT® SYSTEM 50 AL is used in environments with no special demands for chemical resistance or conductivity. The ALSIDENT® SYSTEM 50 AL suction arms consist of aluminium tubes and joints of red, white or black Polypropylene (PP).

Antistatic (AS) – a safe choice for ESD-environments

ALSIDENT® SYSTEM 50 AS suction arms are used in environments with special demands for conductivity, e.g. the sensitive ESD-environments in the electronics industry. The suction arms are equipped with an earthing wire.

The tubes of this version are made of aluminium with a conductive surface treatment. The joints are made of black conductive Polypropylene (PP).

ALSIDENT® SYSTEM 50 AS has been tested and approved for use in  ESD-environments according to IEC 61340-5-1.

ORDER DATA SYSTEM 50-AL

MATERIAL:

Pipe: Aluminium (anodized)

Joint(s) and flange: Polypropylene (PP) white*

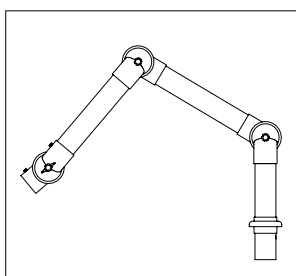
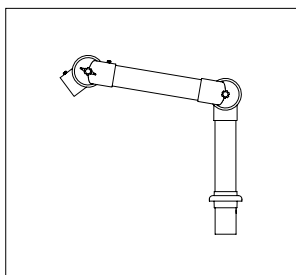

SUCTION ARMS Ø 50 mm

Table mounting (TM), 2 joints

Range (mm)	Weight (kg)	Item No.
275	0.8	10178
375	0.8	10220
475	0.8	10297
575	0.9	10083

* upon request, also available with joints and flange black, red at the same price

Table mounting (TM), 3 joints

Range (mm)	Weight (kg)	Item No.
650	1.1	10307
750	1.2	10172
850	1.3	10318
1050	1.4	10301
1350	1.5	10309

* upon request, also available with joints and flange black, red at the same price

MATERIAL:

Pipe: Aluminium (anodized)

Joint(s) and flange: Polypropylene (PP) white*

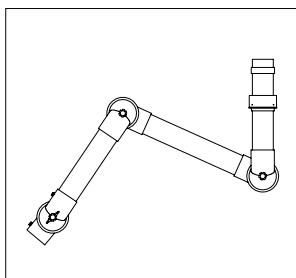
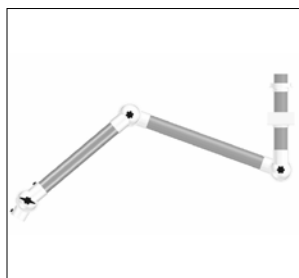
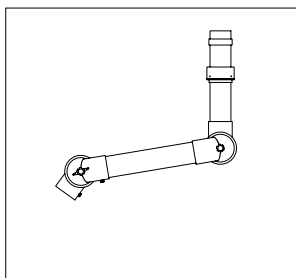

SUCTION ARMS Ø 50 mm

Wall and ceiling mounting (WM/CM), 2 joints

Range (mm)	Weight (kg)	Item No.
275	0.8	10247
375	0.8	10291
475	0.9	10079
575	1.0	10305

* upon request, also available with joints and flange black, red at the same price

Wall and ceiling mounting (WM/CM), 3 joints

Range (mm)	Weight (kg)	Item No.
650	1.1	10310
850	1.3	10081
1050	1.4	10306
1150	1.5	15736
1350	1.6	10316
1750	1.8	12118

* upon request, also available with joints and flange black, red at the same price

ORDER DATA SYSTEM 50-AL-FLEX

MATERIAL:

Hose: Polystyrene (PS) conductive, black

Pipes and suction tips: Aluminium (anodized)

Joint(s) and flange: Polypropylene (PP) black*

WARNING! Only available with suction tips, no alternative collection elements are possible.

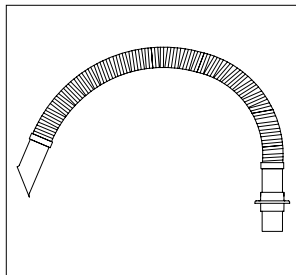

SUCTION ARMS Ø 50 mm

Table mounting (TM), without joint

Range (mm)	Weight (kg)	Item No.
600	0.7	13331

* upon request, also available with joints and flange white, red

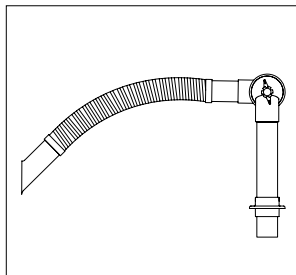

Table mounting (TM), 1 joint

Range (mm)	Weight (kg)	Item No.
700	0.8	13557

* upon request, also available with joints and flange white, red

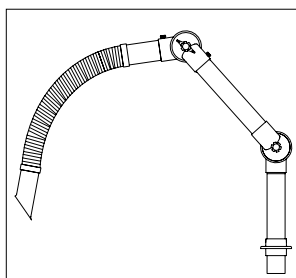

Table mounting (TM), 2 joints

Range (mm)	Weight (kg)	Item No.
900	0.9	13513

* upon request, also available with joints and flange white, red

COLLECTION ELEMENTS SYSTEM 50-AL

MATERIAL:

Pipe: Aluminium (anodized)

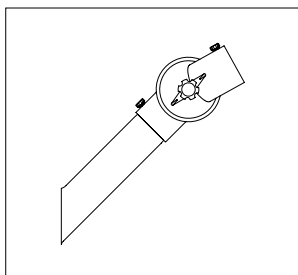

SUCTION TIP FOR SUCTION ARM

Length (mm)	Item No.
210	10199

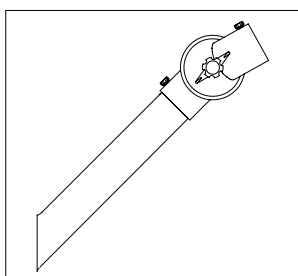

SUCTION TIP FOR SUCTION ARM

Length (mm)	Item No.
310	10294

MATERIAL:

Suction column: Aluminium (anodized)

Pipe sockets: Aluminium (anodized)

Flange: Polypropylene (PP) white*

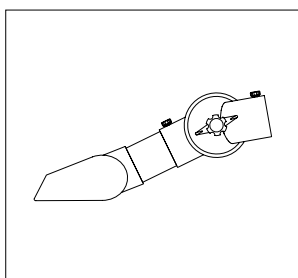

SUCTION COLUMN FOR SUCTION ARM

Width (mm)	Item No.
100	10292

* upon request, also available with flange red, black at the same price - see SYSTEM 50-AS

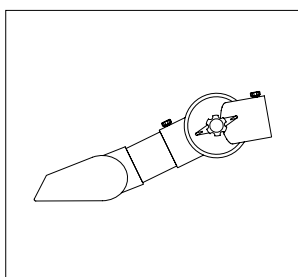

SUCTION COLUMN FOR SUCTION ARM

Width (mm)	Item No.
200	10299

* upon request, also available with flange red, black at the same price - see SYSTEM 50-AS

COLLECTION ELEMENTS SYSTEM 50-AL

MATERIAL:

Flat screen: PETG transparent

Flange: Polypropylene (PP) white*

Pipe sockets: Aluminium (anodized)

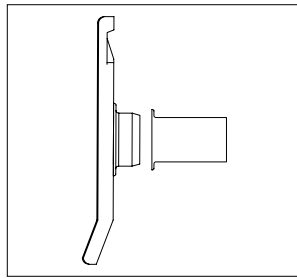

FLAT SCREEN FOR SUCTION ARM

Comprised of: 1x flat screen, 1x pipe sockets

Dimensions (mm)	Item No.
330x240	13279

* upon request, also available with flange black, red at the same price

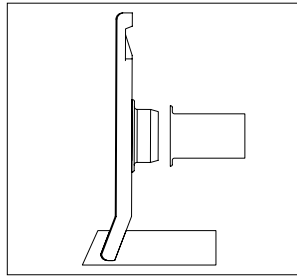
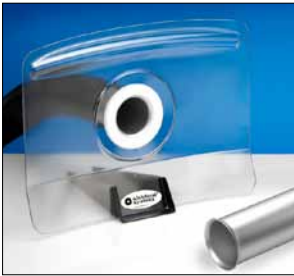

FLAT SCREEN FOR SUCTION ARM

Comprised of:
1x holder, 1x flat screen, 1x pipe sockets

Dimensions (mm)	Item No.
330x240	15396

* upon request, also available with flange black, red at the same price

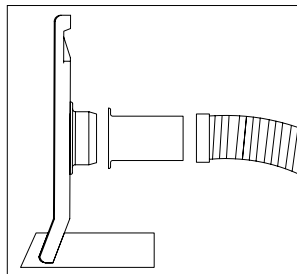
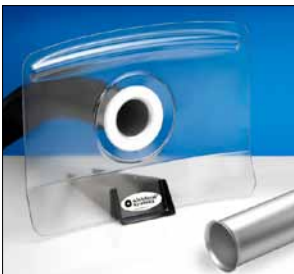

FLAT SCREEN FOR SUCTION ARM

Comprised of: 1x holder, 1x flat screen,
1x pipe sockets, 1.25 m flexible hose

Dimensions (mm)	Item No.
330x240	15397

* upon request, also available with flange black, red at the same price

MATERIAL:

Round hood: Aluminium white* (powder-coated)

Flange: Polypropylene (PP) white*

Pipe sockets: Aluminium (anodized)

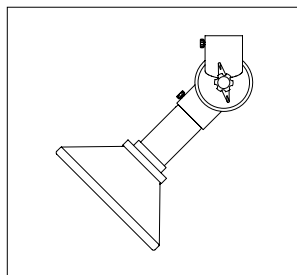

SUCTION HOOD FOR SUCTION ARM

Ø (mm)	Item No.
200	10278

* upon request, also available with hood and flange red at the same price

COLLECTION ELEMENTS SYSTEM 50-AL

MATERIAL:

Round hood: PETG transparent

Flange: Polypropylene (PP) white*

Pipe sockets: Aluminium (anodized)

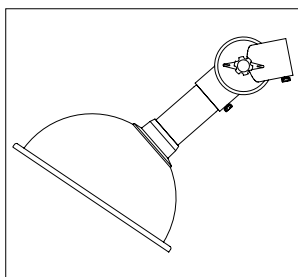

SUCTION HOOD FOR SUCTION ARM

Ø (mm)	Item No.
280	11255

* upon request, also available with flange black, red at the same price

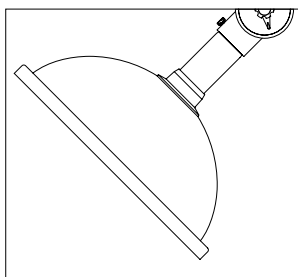

SUCTION HOOD FOR SUCTION ARM

Ø (mm)	Item No.
385	10359

* upon request, also available with flange black, red at the same price

MATERIAL:

Square hood: PETG transparent

Flange: Polypropylene (PP) white*

Pipe sockets: Aluminium (anodized)

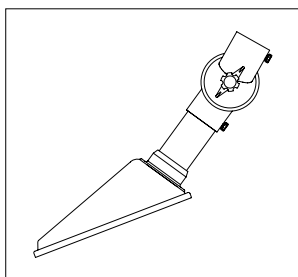

SUCTION HOOD FOR SUCTION ARM

Dimensions (mm)	Item No.
245x220	10308

* upon request, also available with flange black, red at the same price

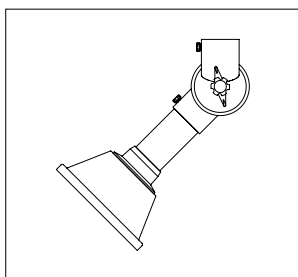

SUCTION HOOD FOR SUCTION ARM

Dimensions (mm)	Item No.
200x150	10311

* upon request, also available with flange black, red at the same price

COLLECTION ELEMENTS SYSTEM 50-AL

MATERIAL:

Hood: Polypropylene (PP) white*

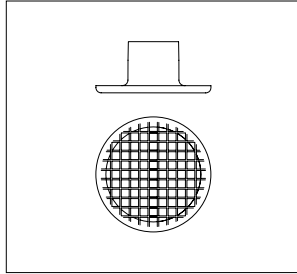

PROTECTIVE SCREEN FOR HOOD

Ø (mm)	Item No.
50	11243

* also available in black (see SYSTEM 50-AS)

HOLDER AND BASE BOX SYSTEM 50-AL

MATERIAL:

Holder: Steel white* (powder-coated)

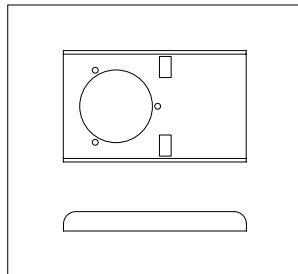

DESK HOLDER

Use	Item No.
System 50	10179

* also available in black (see SYSTEM 50-AS)

MATERIAL:

Bracket: Steel white* (powder-coated)

Flange: Polypropylene (PP) white

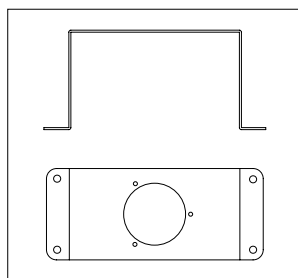
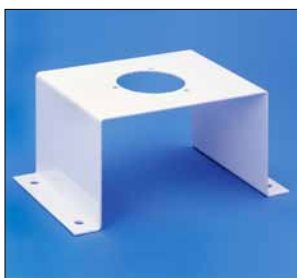

DESK BRACKET

Use	Item No.
System 50	11649

MATERIAL:

Bracket: Steel white* (powder-coated)

Connection: Ø 80 mm

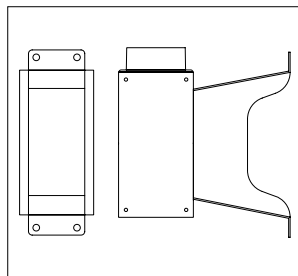

WALL HOLDER

Use	Item No.
System 50	14664

* also available in black (see SYSTEM 50-AS)

HOLDER AND BASE BOX SYSTEM 50-AL

MATERIAL:

Bracket: Steel white* (powder-coated)

Lateral connection: Ø 80 mm

Connection, top: max. Ø 100 mm

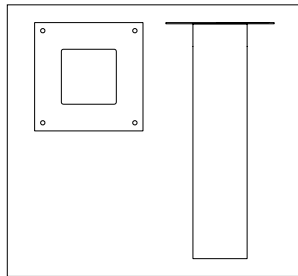

CEILING HOLDER

Length (mm)	Weight (kg)	Item No.
250	2.0	15000**
250	2.0	11101
500	3.0	10207
750	3.8	10208
1000	4.5	10215
1250	5.4	15443
1500	6.1	15444
1750	7.1	15445
2000	7.9	15446

* also available in black (see SYSTEM 50-AS)

** only top connection, max Ø 100 mm

MATERIAL:

Holder: Steel white* (powder-coated)

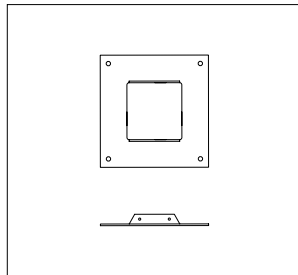
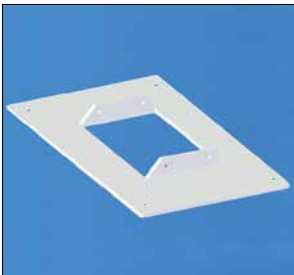

AMPLIFIER HOLDER FOR BASE BOX L ≥ 2000 mm

Dimensions (mm)	Item No.
Internal: 100x100 External: 200x200	15581

MATERIAL:

Frame: Polystyrene (PS) white

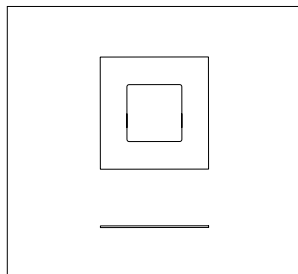
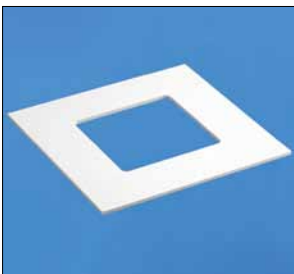

DECORATION FLANGE / COVER FRAME FOR BASE BOX

Dimensions (mm)	Item No.
Internal: 100x100 External: 200x200	15577

FURTHER ACCESSORIES SYSTEM 50-AL

MATERIAL:

Socket: Polyvinyl chloride (PVC) black

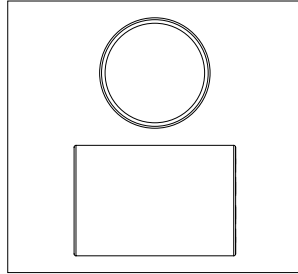

HOSE CONNECTION FOR SUCTION ARM

Connection socket for hose set DN 50 (internal Ø 44 mm)

Use	Item No.
System 50	15639

MATERIAL:

Socket Polypropylene (PP) white*

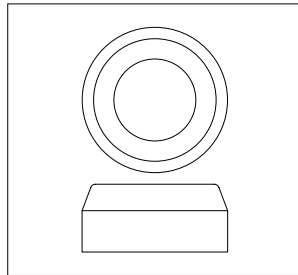

REDUCING SOCKET

Ø (mm)	Item No.
63-50	10348
80-50	10443

* also available in black (see SYSTEM 50-AS)

MATERIAL:

Bracket: Steel white* (powder-coated)

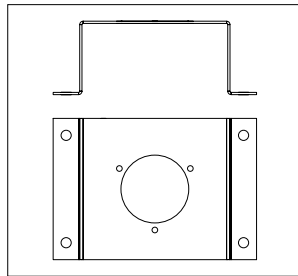

ADAPTION SET FOR SUCTION ARM

Comprised of: 1x bracket, 1x flange

Use	Item No.
LN 100	13193
LN 230, GL230	13191
LN 260, LN 265	13194
Compair S, Compair SD	13218
BF Series	See BF Series catalogue for all available suction arm variants

ORDER DATA SYSTEM 50-AS

MATERIAL:

Pipe: Aluminium (chromated)

Joint(s) and flange: Polypropylene (PP) conductive, black

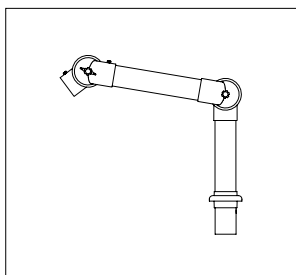

SUCTION ARMS Ø 50 mm

Table mounting (TM), 2 joints

Range (mm)	Weight (kg)	Item No.
275	0.8	15452
375	0.8	10403
475	0.8	11153

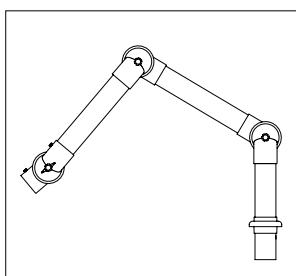

Table mounting (TM), 3 joints

Range (mm)	Weight (kg)	Item No.
650	1.1	10409
850	1.3	10389
1050	1.4	15051

MATERIAL:

Pipe: Aluminium (chromated)

Joint(s) and flange: Polypropylene (PP) conductive, black

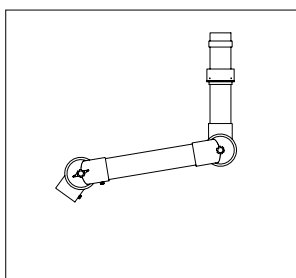

SUCTION ARMS Ø 50 mm

Wall and ceiling mounting (WM/CM), 2 joints

Range (mm)	Weight (kg)	Item No.
375	0.8	15453
475	0.9	15454

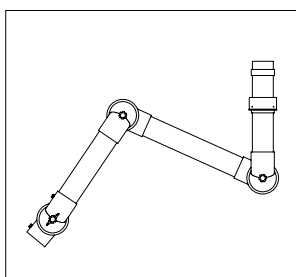
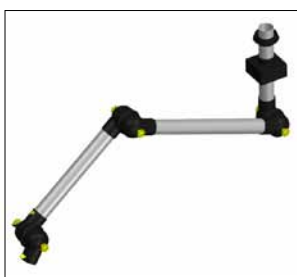

Wall and ceiling mounting (WM/CM), 3 joints

Range (mm)	Weight (kg)	Item No.
650	1.1	11521
850	1.3	11528
1050	1.4	11531
1350	1.6	11535

ORDER DATA SYSTEM 50-AS-FLEX

MATERIAL:

Hose: Polystyrene (PS) conductive, black

Pipes and suction tips: Aluminium (chromated)

Joint(s) and flange: Polypropylene (PP) conductive, black

WARNING! Only available with suction tips, no alternative collection elements are possible.

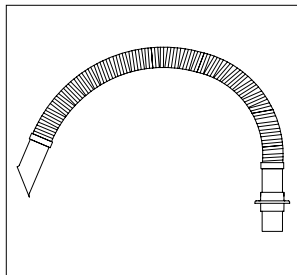

SUCTION ARMS Ø 50 mm

Table mounting (TM), without joint

Range (mm)	Weight (kg)	Item No.
600	0.7	15608

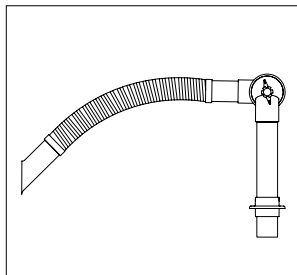

Table mounting (TM), 1 joint

Range (mm)	Weight (kg)	Item No.
700	0.9	12992

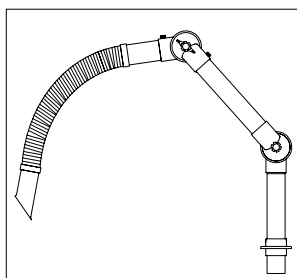

Table mounting (TM), 2 joints

Range (mm)	Weight (kg)	Item No.
900	1.2	14615

COLLECTION ELEMENTS SYSTEM 50-AS

MATERIAL:

Pipe: Aluminium (chromated)

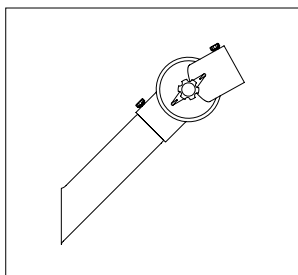

SUCTION TIP FOR SUCTION ARM

Length (mm)	Item No.
210	10392

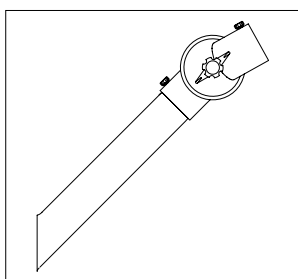

SUCTION TIP FOR SUCTION ARM

Length (mm)	Item No.
310	10400

MATERIAL:

Suction column: Aluminium (chromated)

Pipe sockets: Aluminium (chromated)

Flange: Polypropylene (PP) conductive, black

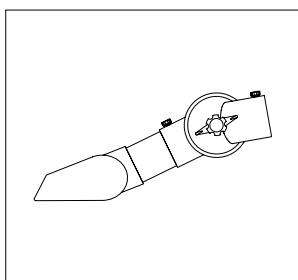

SUCTION COLUMN FOR SUCTION ARM

Width (mm)	Item No.
100	15455

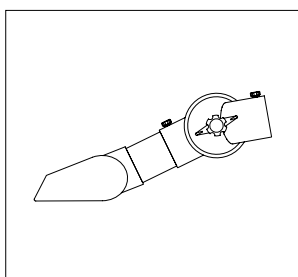

SUCTION COLUMN FOR SUCTION ARM

Width (mm)	Item No.
200	10395

COLLECTION ELEMENTS SYSTEM 50-AS

MATERIAL:

Round hood: Aluminium (chromated)

Flange: Polypropylene (PP) conductive, black

Pipe sockets: Aluminium (chromated)

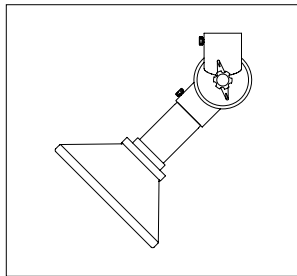

SUCTION HOOD FOR SUCTION ARM

Ø (mm)	Item No.
200	11431

MATERIAL:

Round hood: Polypropylene (PP) conductive, black

Flange: Polypropylene (PP) conductive, black

Pipe sockets: Aluminium (chromated)

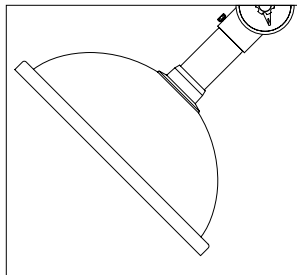

SUCTION HOOD FOR SUCTION ARM

Ø (mm)	Item No.
385	15456

MATERIAL:

Flat screen: Polypropylene (PP) conductive, black

Flange: Polypropylene (PP) conductive, black

Pipe sockets: Aluminium (chromated)

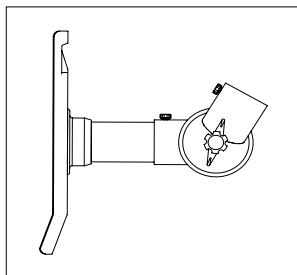

FLAT SCREEN FOR SUCTION ARM

Dimensions (mm)	Item No.
330x240	13314

COLLECTION ELEMENTS SYSTEM 50-AS

MATERIAL:

Hood: Polypropylene (PP) conductive, black

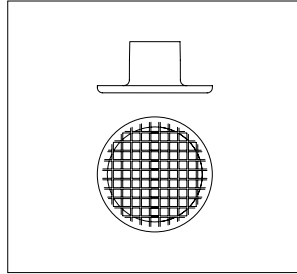

PROTECTIVE SCREEN FOR HOOD

Ø (mm)	Item No.
50	15741

HOLDER AND BASE BOX SYSTEM 50-AS

MATERIAL:

Holder: Steel black (powder-coated)

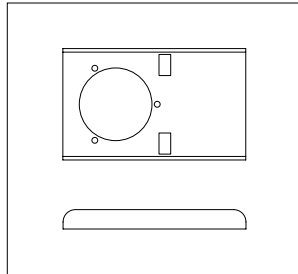

DESK HOLDER

Use	Item No.
System 50	13514

MATERIAL:

Bracket: Steel white* (powder-coated)

Flange: Polypropylene (PP) white

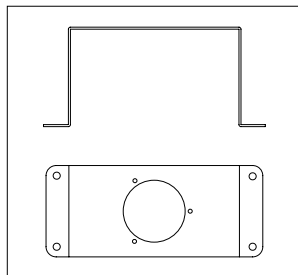

DESK BRACKET

Use	Item No.
System 50	11649

MATERIAL:

Bracket: Steel black (powder-coated)

Connection: Ø 80 mm

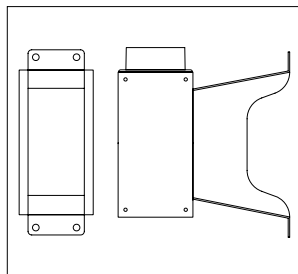

WALL HOLDER

Use	Item No.
System 50	15406

HOLDER AND BASE BOX SYSTEM 50-AS

MATERIAL:

Bracket: Steel black (powder-coated)

Lateral connection: Ø 80 mm

Connection, top: max. Ø 100 mm

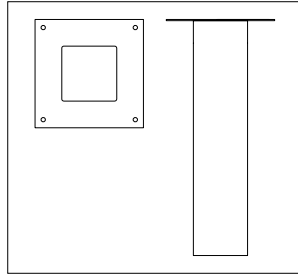

CEILING HOLDER

Length (mm)	Weight (kg)	Item No.
250	2.0	15447*
250	2.0	15465
500	3.0	15448
750	3.8	15449
1000	4.5	15450

* only top connection, max Ø 100 mm

FURTHER ACCESSORIES SYSTEM 50-AS

MATERIAL:

Socket Polyvinyl chloride (PVC) black

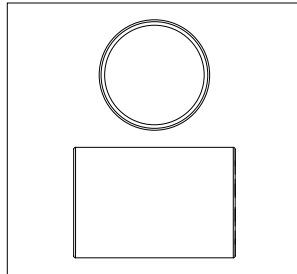

HOSE CONNECTION FOR SUCTION ARM

Connection socket for hose set DN 50 (internal Ø 44 mm)

Use	Item No.
System 50	15639

MATERIAL:

Socket Polypropylene (PP) black

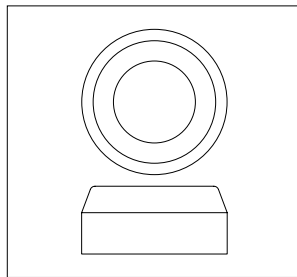

REDUCING SOCKET

Ø (mm)	Item No.
63-50	15440
80-50	15441

MATERIAL:

Bracket: Steel white (powder-coated)

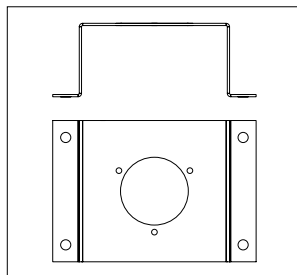

ADAPTION SET FOR SUCTION ARM

Comprised of: 1x bracket, 1x flange

Use	Item No.
LN 100	13193
LN 230, GL230	13191
LN 260, LN 265	13194
Compair S, Compair SD	13218
BF Series	See BF Series catalogue for all available suction arm variants



PEOPLE / ENVIRONMENT / MACHINERY // TRIPLE PROTECTION

ALSIDENT® SYSTEM 63 is suited for air volumes between 60-120 m³/h.

ALSIDENT® SYSTEM 63 is very applicable in various trades where a chemical resistant suction arm is needed, such as laboratories, chemical industries, schools, high schools and universities.

Adjusted to the work conditions

ALSIDENT® SYSTEM 63 suction arms are quickly mounted with standard brackets for table, wall or ceiling.

The standard ALSIDENT® SYSTEM 63 arms are available in various types that are complementary to each other with reaches up to 1500 mm (59.06"). It is therefore possible to choose a suction arm adapted for each work situation.

The suction arms are fitted with throttle valves to regulate the volume flow.

Material

ALSIDENT® SYSTEM 63 is used in work areas with special requirements for chemical resistance because of the type of pollution, e.g. chemical fumes. Therefore, the tubes and joints of this material version are made of white Polypropylene (PP).

ORDER DATA SYSTEM 63-CB

MATERIAL:

Pipe: Polypropylene (PP) white

Joint(s) and flange: Polypropylene (PP) white

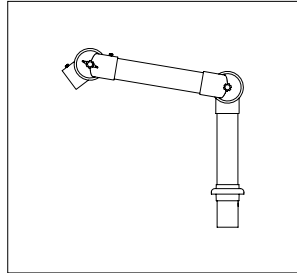

SUCTION ARMS Ø 63 mm

Table mounting (TM), 2 joints

Range (mm)	Weight (kg)	Item No.
350	0.7	15742
450	0.75	14120
550	0.8	15743

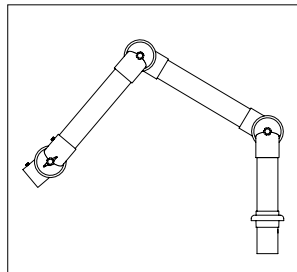

Table mounting (TM), 3 joints

Range (mm)	Weight (kg)	Item No.
700	1.0	13684
1000	1.4	13648

MATERIAL:

Pipe: Polypropylene (PP) white

Joint(s) and flange: Polypropylene (PP) white

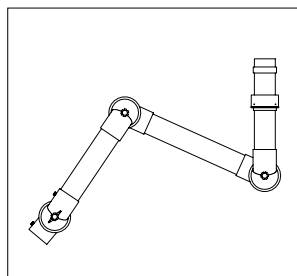

SUCTION ARMS Ø 63 mm

Wall and ceiling mounting (WM/CM), 3 joints

Range (mm)	Weight (kg)	Item No.
700	1.3	15744
1000	1.4	13850
1200	1.45	15745
1250	1.5	15746
1550	1.6	13851

COLLECTION ELEMENTS SYSTEM 63-CB

MATERIAL:

Pipe and tip: Polypropylene (PP) white

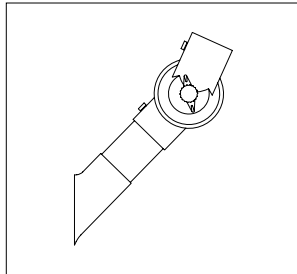

SUCTION TIP FOR SUCTION ARM

Length (mm)	Item No.
250	13649

MATERIAL:

Round hood: PETG transparent

Flange: Polypropylene (PP) white

Pipe sockets: Polypropylene (PP) white

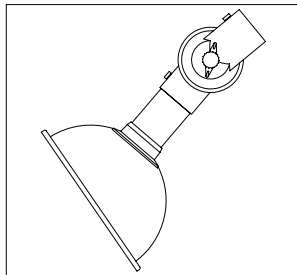

SUCTION HOOD FOR SUCTION ARM

Ø (mm)	Item No.
280	13852

MATERIAL:

Round hood: PETG transparent

Flange: Polypropylene (PP) white

Pipe sockets: Polypropylene (PP) white

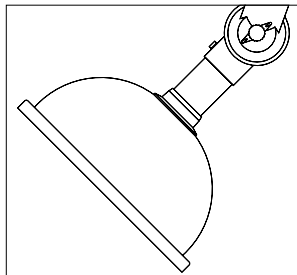

SUCTION HOOD FOR SUCTION ARM

Ø (mm)	Item No.
385	13853

COLLECTION ELEMENTS SYSTEM 63-CB

MATERIAL:

Round hood: Polypropylene (PP) white

Flange: Polypropylene (PP) white

Pipe sockets: Polypropylene (PP) white

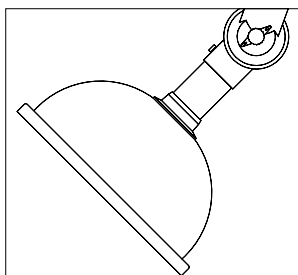

SUCTION HOOD FOR SUCTION ARM

Ø (mm)	Item No.
385	15747

MATERIAL:

Square hood: PETG transparent

Flange: Polypropylene (PP) white

Pipe sockets: Polypropylene (PP) white

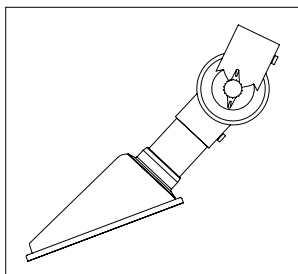

SUCTION HOOD FOR SUCTION ARM

Dimensions (mm)	Item No.
295x250	15748

MATERIAL:

Flat screen: PETG transparent

Flange: Polypropylene (PP) white

Pipe sockets: Polypropylene (PP) white

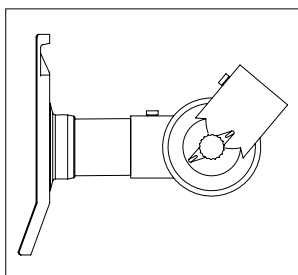

FLAT SCREEN FOR SUCTION ARM

Dimensions (mm)	Item No.
330x240	15749

MATERIAL:

Flat screen: Polypropylene (PP) white

Flange: Polypropylene (PP) white

Pipe sockets: Polypropylene (PP) white

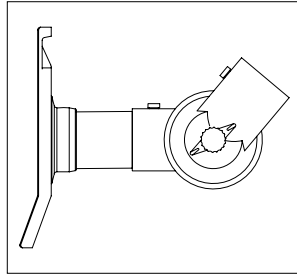

FLAT SCREEN FOR SUCTION ARM

Dimensions (mm)	Item No.
330x240	15750

HOLDER AND BASE BOX SYSTEM 63-CB

MATERIAL:

Holder: Steel white (powder-coated)

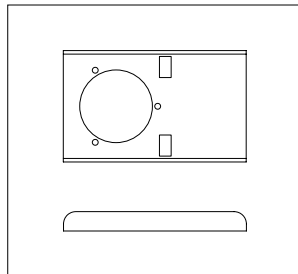

DESK HOLDER

Use	Item No.
System 63	14121

MATERIAL:

Bracket: Steel white (powder-coated)

Flange: Polypropylene (PP) white

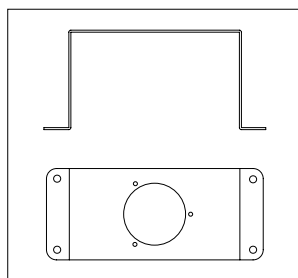
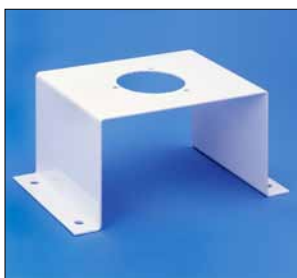

DESK BRACKET

Use	Item No.
System 63	15751

MATERIAL:

Bracket: Steel white (powder-coated)

Connection: Ø 80 mm

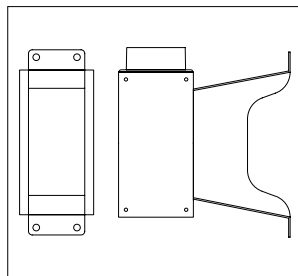

WALL HOLDER

Use	Item No.
System 63	14670

HOLDER AND BASE BOX SYSTEM 63-CB

MATERIAL:

Bracket: Steel white (powder-coated)

Lateral connection: Ø 80 mm

Connection, top: max. Ø 100 mm

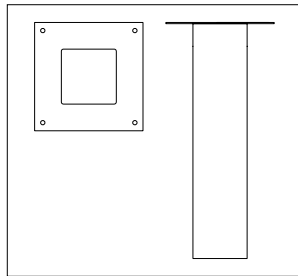

CEILING HOLDER

Length (mm)	Weight (kg)	Item No.
250	2.0	15000*
250	2.0	11101
500	3.0	10207
750	3.8	10208
1000	4.5	10215
1250	5.4	15443
1500	6.1	15444
1750	7.1	15445
2000	7.9	15446

* only top connection, max Ø 100 mm

MATERIAL:

Holder: Steel white (powder-coated)

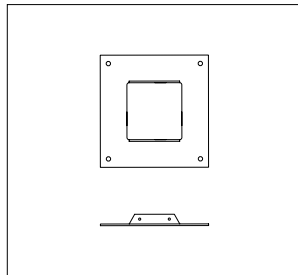
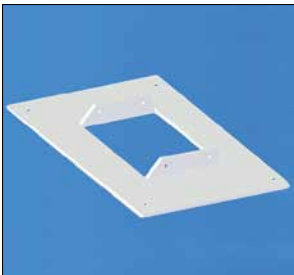

AMPLIFIER HOLDER FOR BASE BOX L ≥ 2000 mm

Dimensions (mm)	Item No.
Internal: 100x100 External: 200x200	15581

MATERIAL:

Frame: Polystyrene (PS) white

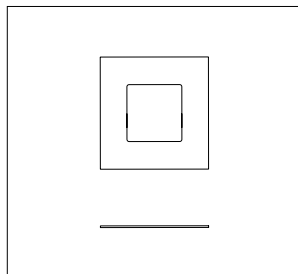
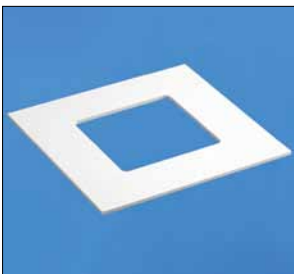

DECORATION FLANGE / COVER FRAME FOR BASE BOX

Dimensions (mm)	Item No.
Internal: 100x100 External: 200x200	15577

FURTHER ACCESSORIES SYSTEM 63-CB

MATERIAL:

Socket Polypropylene (PP) white

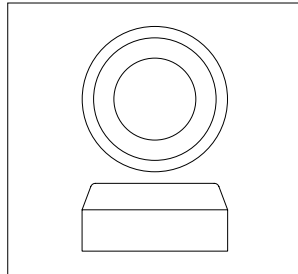

REDUCING SOCKET

Ø (mm)	Item No.
80-63	13857
100-63	13858

MATERIAL:

Bracket: Steel white (powder-coated)

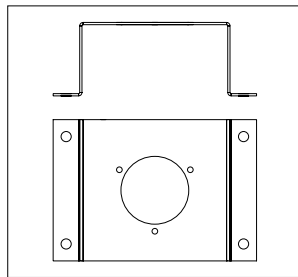

ADAPTION SET FOR SUCTION ARM

Comprised of: 1x bracket, 1x flange

Use	Item No.
LN 100	14127
LN 230, GL230	14128
LN 260, LN 265	14129
Compair S, Compair SD	14130
BF Series	See BF Series catalogue for all available suction arm variants

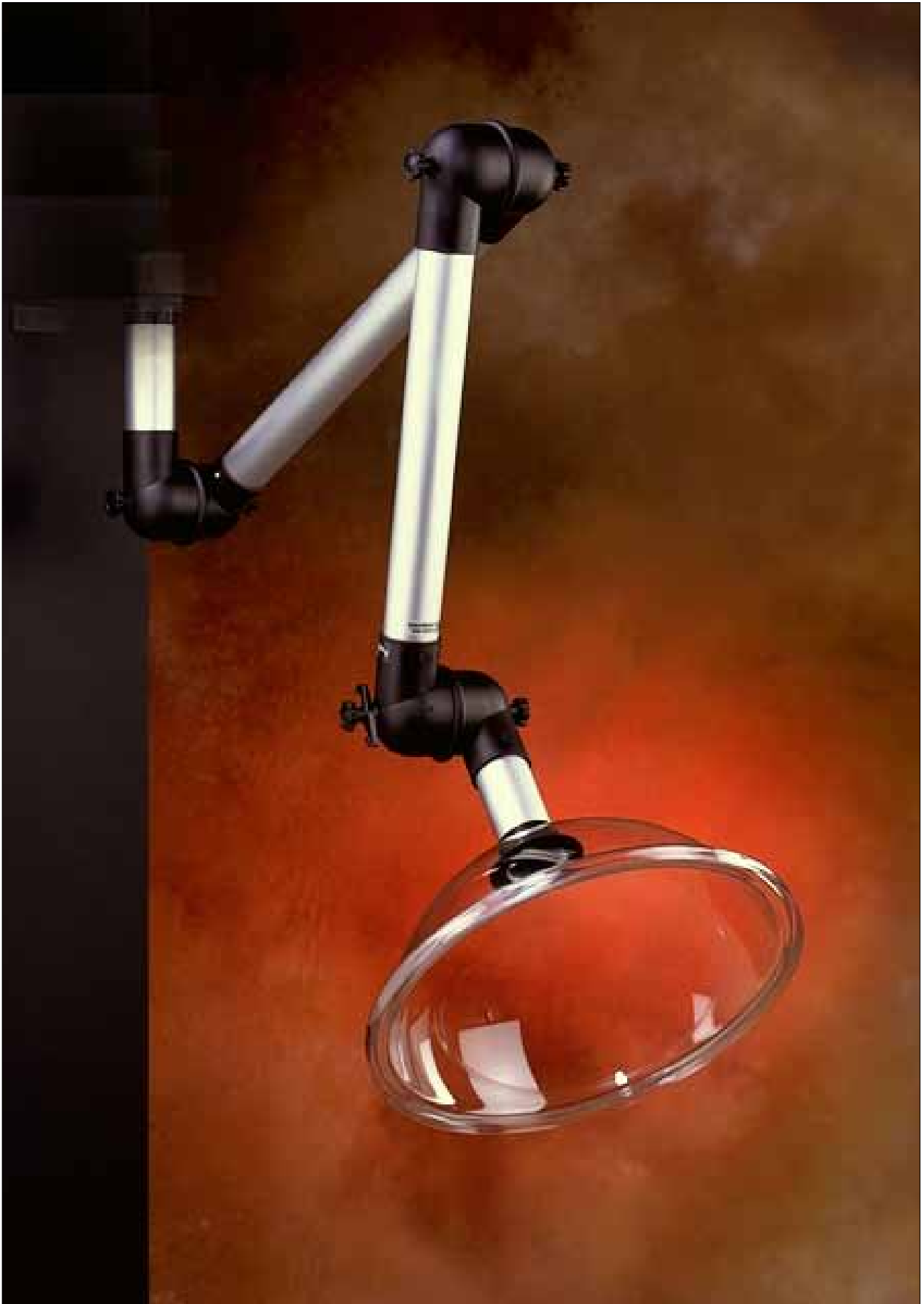

PEOPLE / ENVIRONMENT / MACHINERY // TRIPLE PROTECTION

ALSIDENT® SYSTEM 75 is suited for air volumes between 80-180 m³/h (45-105 CFM).

Depending on material version, ALSIDENT® SYSTEM 75 is very applicable in trades such as laser techniques, laboratories, chemical industries, pharmaceutical industries, the food industry, vocational schools, universities and machine shops.

Adjusted to the work conditions

The ALSIDENT® SYSTEM 75 fume suction arms are quickly mounted with standard brackets for table, wall or ceiling.

The standard ALSIDENT® SYSTEM 75 is available in various types that are complementary to each other with reaches up to 1,990 mm (78.35"). Therefore it is possible to choose an extraction arm applicable for each work situation.

Material Versions

ALSIDENT® SYSTEM 75 is available in three material versions – aluminium (AL), antistatic (AS) and chemical resistant (CR). The choice of material version depends on each work process and type of pollution.

The suction arms are fitted with throttle valves to regulate the volume flow.

Aluminium (AL) – For most applications

ALSIDENT® SYSTEM 75 AL is used in environments with no special demands for chemical resistance or conductivity. The ALSIDENT® SYSTEM 75 AL suction arms consist of aluminium tubes and joints of red or white Polypropylene (PP).

Antistatic (AS) – A safe choice for ESD and EX-environments

ALSIDENT® SYSTEM 75 AS suction arms are used in environments with special demands for conductivity, e.g. in sensitive ESD-environments or in environments with explosive atmosphere. The suction arms are delivered with an earthing wire.

The tubes and joints of the antistatic version are made of black conductive Polypropylene (PP).

ALSIDENT® SYSTEM 75 AS has been tested and approved for use in ESD-environments according to IEC 61340-5-1. ALSIDENT® SYSTEM 75 has also been approved for use in explosive areas and is marked:

EX II 1 GD

Chemical Resistant (PP) – for aggressive areas

The ALSIDENT® SYSTEM 75 Chemical Resistant (PP) suction arms are used in work areas with special requirements for chemical resistance because of the type of pollution, e.g. chemical fumes. The tubes and joints of this material version are made of white Polypropylene (PP).

ORDER DATA SYSTEM 75-AL

MATERIAL:

Pipe: Aluminium (anodized)

Joint(s) and flange: Polypropylene (PP) white*

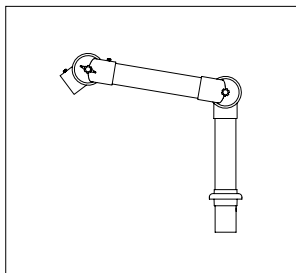

SUCTION ARMS Ø 75 mm

Table mounting (TM), 2 joints

Range (mm)	Weight (kg)	Item No.
350	1.5	11540
450	2.0	15457
550	2.3	11226

* upon request, also available with joints and flange red at the same price

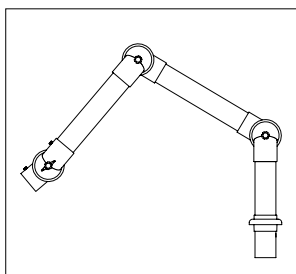
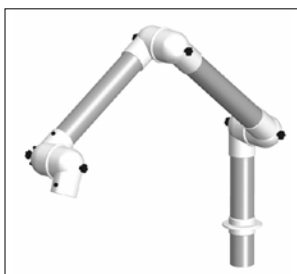

Table mounting (TM), 3 joints

Range (mm)	Weight (kg)	Item No.
700	1.9	10078
1000	2.5	10072
1200	2.7	10190
1550	3.0	10197

* upon request, also available with joints and flange red at the same price

MATERIAL:

Pipe: Aluminium (anodized)

Joint(s) and flange: Polypropylene (PP) white*

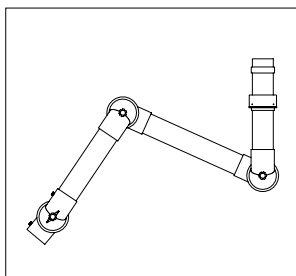
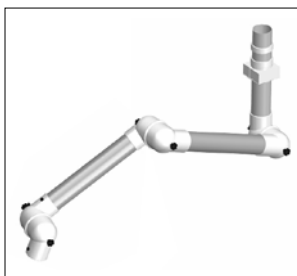

SUCTION ARMS Ø 75 mm

Wall and ceiling mounting (WM/CM), 3 joints

Range (mm)	Weight (kg)	Item No.
700	2.0	10182
1000	2.6	10186
1200	2.8	10189
1250	2.3	15474
1550	3.1	10196
1550**	3.4	15475
1800	3.6	14724
1800***	3.8	14754

* upon request, also available with joints and flange red at the same price

** with 1x external gas spring

*** with 2x external gas springs

COLLECTION ELEMENTS SYSTEM 75-AL

MATERIAL:

Pipe: Aluminium (anodized)

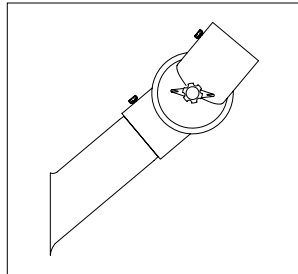

SUCTION TIP FOR SUCTION ARM

Length (mm)	Item No.
250	10213

MATERIAL:

Suction column: Aluminium (anodized)

Pipe sockets: Aluminium (anodized)

Flange: Polypropylene (PP) white*

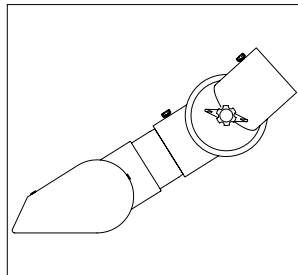

SUCTION COLUMN FOR SUCTION ARM

Width (mm)	Item No.
250	10237

** upon request, also available with flange red at the same price*

MATERIAL:

Round hood: Aluminium white* (powder-coated)

Flange: Polypropylene (PP) white*

Pipe sockets: Aluminium (anodized)

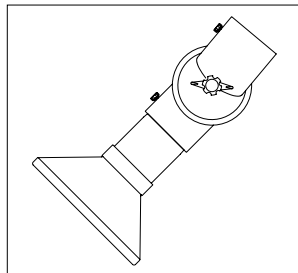

SUCTION HOOD FOR SUCTION ARM

Ø (mm)	Item No.
200	10219

** upon request, also available with hood and flange red at the same price*

COLLECTION ELEMENTS SYSTEM 75-AL

MATERIAL:

Round hood: Aluminium (anodized)

Flange: Aluminium (anodized)

Pipe sockets: Aluminium (anodized)

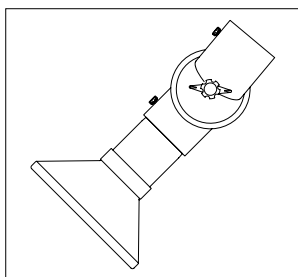

SUCTION HOOD FOR SUCTION ARM

Ø (mm)	Item No.
200	15476

MATERIAL:

Round hood: PETG transparent

Flange: Polypropylene (PP) white*

Pipe sockets: Aluminium (anodized)

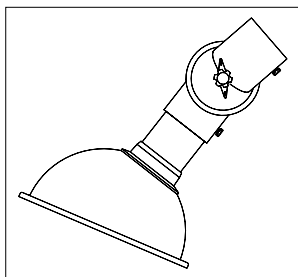

SUCTION HOOD FOR SUCTION ARM

Ø (mm)	Item No.
280	11275

* upon request, also available with flange red at the same price

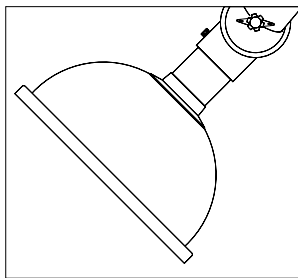

SUCTION HOOD FOR SUCTION ARM

Ø (mm)	Item No.
385	10412

* upon request, also available with flange red at the same price

COLLECTION ELEMENTS SYSTEM 75-AL

MATERIAL:

Square hood: PETG transparent
 Flange: Polypropylene (PP) white*
 Pipe sockets: Aluminium (anodized)

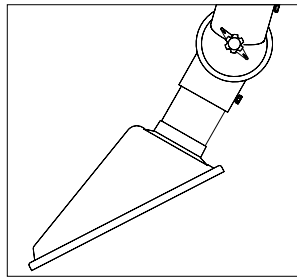

SUCTION HOOD FOR SUCTION ARM

Dimensions (mm)	Item No.
420x320	10234

* upon request, also available with flange red at the same price

MATERIAL:

Flat screen: PETG transparent
 Flange: Polypropylene (PP) white*
 Pipe sockets: Aluminium (anodized)

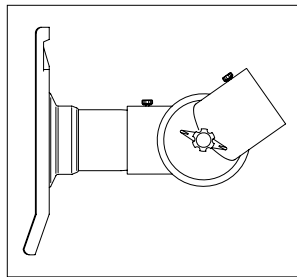

FLAT SCREEN FOR SUCTION ARM

Comprised of: 1x flat screen, 1x pipe sockets

Dimensions (mm)	Item No.
330x240	14355

* upon request, also available with flange red at the same price

MATERIAL:

Hood: Polypropylene (PP) white*

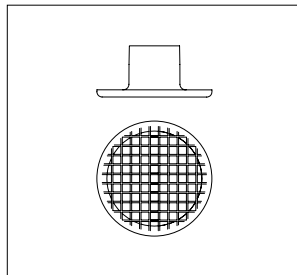

PROTECTIVE SCREEN FOR HOOD

Ø (mm)	Item No.
75	11228

* also available in black (see SYSTEM 75-AS)

HOLDER AND BASE BOX SYSTEM 75-AL

MATERIAL:

Holder: Steel white* (powder-coated)

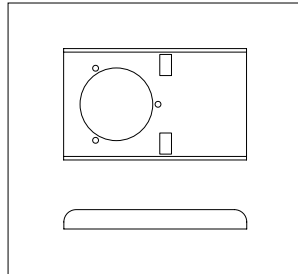

DESK HOLDER

Use	Item No.
System 75	10202

* also available in black (see SYSTEM 75-AS)

MATERIAL:

Bracket: Steel white (powder-coated)

Flange: Polypropylene (PP) white

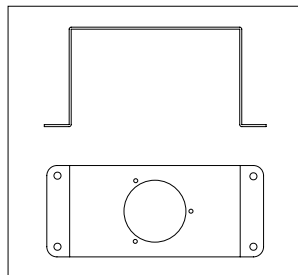
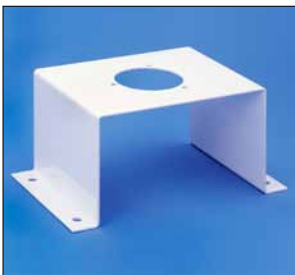

DESK BRACKET

Use	Item No.
System 75	11432

MATERIAL:

Bracket: Steel white* (powder-coated)

Connection: Ø 80 mm

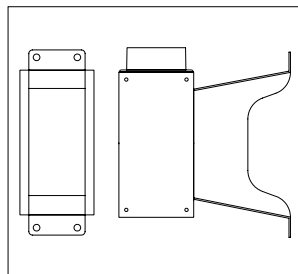

WALL HOLDER

Use	Item No.
System 75	14671

* also available in black (see SYSTEM 75-AS)

HOLDER AND BASE BOX SYSTEM 75-AL

MATERIAL:

Bracket: Steel white* (powder-coated)

Lateral connection: Ø 80 mm

Connection, top: max. Ø 100 mm

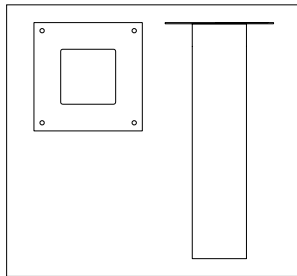

CEILING HOLDER

Length (mm)	Weight (kg)	Item No.
250	2.0	15000**
500	3.0	10207
750	3.8	10208
1000	4.5	10215
1250	5.4	15443
1500	6.1	15444
1750	7.1	15445
2000	7.9	15446

* also available in black (see SYSTEM 75-AS)
** only top connection, max Ø 100 mm

MATERIAL:

Holder: Steel white (powder-coated)

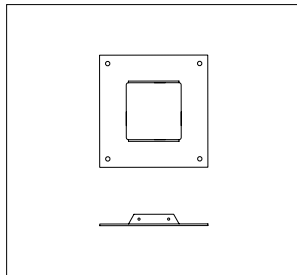
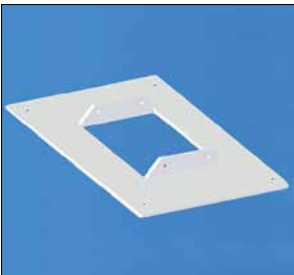

AMPLIFIER HOLDER FOR BASE BOX L ≥ 2000 mm

Dimensions (mm)	Item No.
Internal: 100x100 External: 200x200	15581

MATERIAL:

Frame: Polystyrene (PS) white

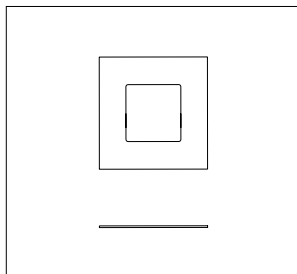
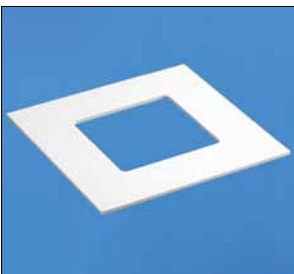

DECORATION FLANGE / COVER FRAME FOR BASE BOX

Dimensions (mm)	Item No.
Internal: 100x100 External: 200x200	15577

FURTHER ACCESSORIES SYSTEM 75-AL

MATERIAL:

Socket Polypropylene (PP) white*

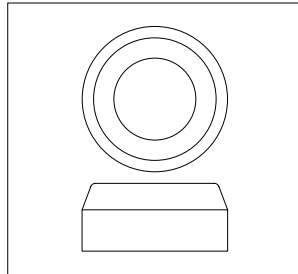

REDUCING SOCKET

Ø (mm)	Item No.
80-75	14180
100-75	10346

* also available in black (see SYSTEM 75-AS)

MATERIAL:

Bracket: Steel white (powder-coated)

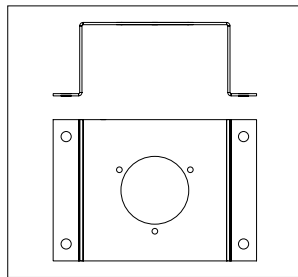

ADAPTION SET FOR SUCTION ARM

Comprised of: 1x bracket, 1x flange

Use	Item No.
LN 230, GL230	13192
LN 260, LN 265, GL 265, GL 400	13195
BF Series	See BF Series catalogue for all available suction arm variants

ORDER DATA SYSTEM 75-AS

MATERIAL:

Pipe: Polypropylene (PP) conductive, black

Joint(s) and flange: Polypropylene (PP) conductive, black

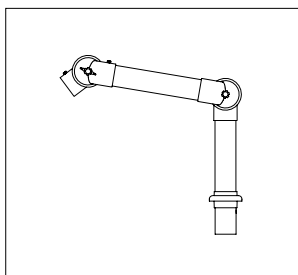

SUCTION ARMS Ø 75 mm

Table mounting (TM), 2 joints

Range (mm)	Weight (kg)	Item No.
350	1.5	15469
450	2.0	15470
550	2.5	15471

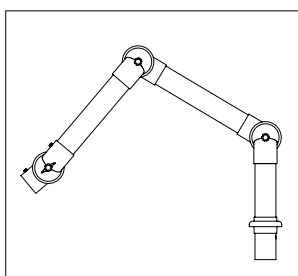

Table mounting (TM), 3 joints

Range (mm)	Weight (kg)	Item No.
700	1.9	14633
1000	2.5	12713
1200	2.7	12847

MATERIAL:

Pipe: Polypropylene (PP) conductive, black

Joint(s) and flange: Polypropylene (PP) conductive, black

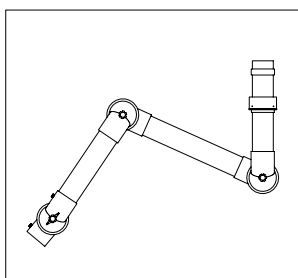

SUCTION ARMS Ø 75 mm

Wall and ceiling mounting (WM/CM), 3 joints

Range (mm)	Weight (kg)	Item No.
700	2.0	15466
1000	2.6	15409
1200	2.8	15408
1250	2.3	15472
1550*	3.4	15127
1800**	4.1	15473

* with 1x external gas spring
 ** with 2x external gas springs

COLLECTION ELEMENTS SYSTEM 75-AS

MATERIAL:

Pipe and tip: Polypropylene (PP) conductive, black

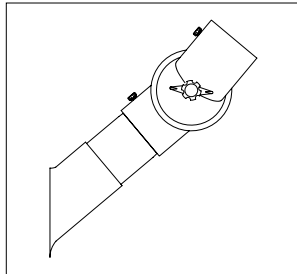

SUCTION TIP FOR SUCTION ARM

Length (mm)	Item No.
250	12591

MATERIAL:

Round hood: Aluminium (chromated)

Flange: Polypropylene (PP) conductive, black

Pipe sockets: Polypropylene (PP) conductive, black

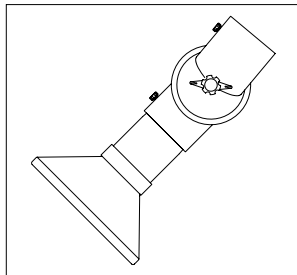

SUCTION HOOD FOR SUCTION ARM

Ø (mm)	Item No.
200	13138

MATERIAL:

Round hood: Polypropylene (PP) conductive, black

Flange: Polypropylene (PP) conductive, black

Pipe sockets: Polypropylene (PP) conductive, black

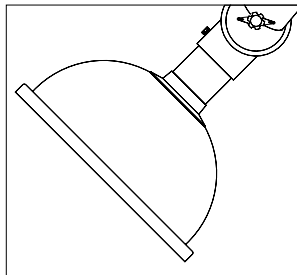

SUCTION HOOD FOR SUCTION ARM

Ø (mm)	Item No.
385	14579

COLLECTION ELEMENTS SYSTEM 75-AS

MATERIAL:

Flat screen: Polypropylene (PP) conductive, black

Flange: Polypropylene (PP) conductive, black

Pipe sockets: Polypropylene (PP) conductive, black

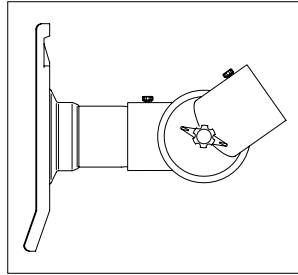

FLAT SCREEN FOR SUCTION ARM

Dimensions (mm)	Item No.
330x240	13298

HOLDER AND BASE BOX SYSTEM 75-AS

MATERIAL:

Holder: Steel black (powder-coated)

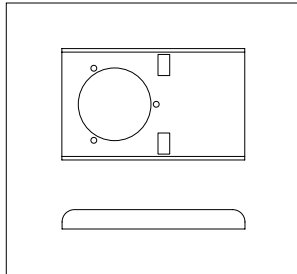

DESK HOLDER

Use	Item No.
System 75	15477

MATERIAL:

Bracket: Steel white (powder-coated)

Flange: Polypropylene (PP) white

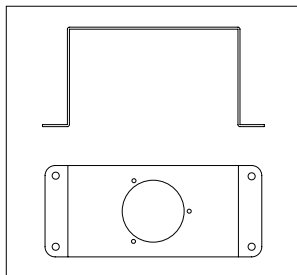
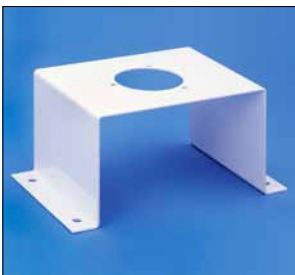

DESK BRACKET

Use	Item No.
System 75	11432

MATERIAL:

Bracket: Steel black (powder-coated)

Connection: Ø 80 mm

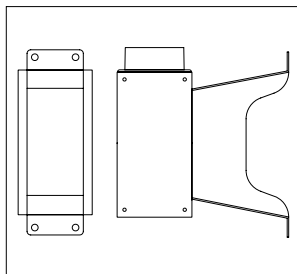

WALL HOLDER

Use	Item No.
System 75	15407

HOLDER AND BASE BOX SYSTEM 75-AS

MATERIAL:

Bracket: Steel black (powder-coated)

Lateral connection: Ø 80 mm

Connection, top: max. Ø 100 mm

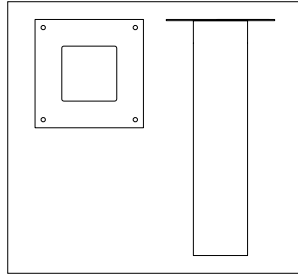

CEILING HOLDER

Length (mm)	Weight (kg)	Item No.
250	2.0	15465*
500	3.0	15448
750	3.8	15449
1000	4.5	15450

* only top connection, max Ø 100 mm

FURTHER ACCESSORIES SYSTEM 75-AS

MATERIAL:

Socket: Polypropylene (PP) black

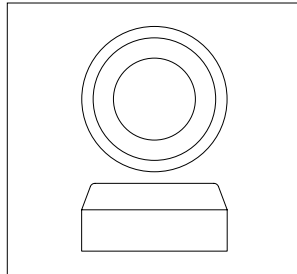
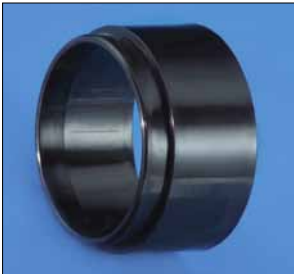

REDUCING SOCKET

Ø (mm)	Item No.
80-75	14609
100-75	15464

MATERIAL:

Bracket: Steel white (powder-coated)

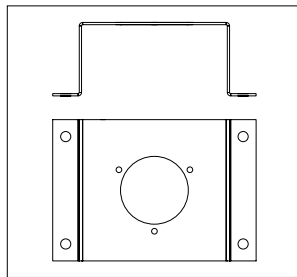

ADAPTION SET FOR SUCTION ARM

Comprised of: 1x bracket, 1x flange

Use	Item No.
LN 230, GL230	13192
LN 260, LN 265, GL 265, GL 400	13195
BF Series	See BF Series catalogue for all available suction arm variants

ORDER DATA SYSTEM 75-CB

MATERIAL:

Pipe: Polypropylene (PP) white

Joint(s) and flange: Polypropylene (PP) white

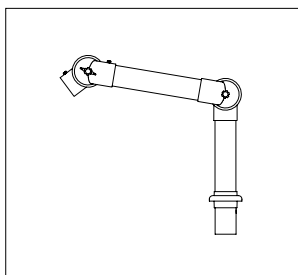

SUCTION ARMS Ø 75 mm

Table mounting (TM), 2 joints

Range (mm)	Weight (kg)	Item No.
350	1.5	15478
450	2.0	15479
550	2.3	15480

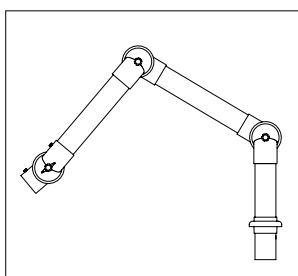

Table mounting (TM), 3 joints

Range (mm)	Weight (kg)	Item No.
700	1.9	10203
1000	2.5	10206
1200	2.7	10183
1550	3.0	10073

MATERIAL:

Pipe: Polypropylene (PP) white

Joint(s) and flange: Polypropylene (PP) white

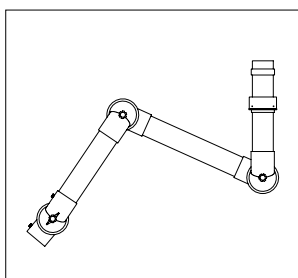

SUCTION ARMS Ø 75 mm

Wall and ceiling mounting (WM/CM), 3 joints

Range (mm)	Weight (kg)	Item No.
700	2.0	10075
1000	2.6	10191
1200	2.8	10195
1250	2.3	15483
1550	3.1	10198
1550*	3.4	15484
1800**	3.8	15485

* with 1x external gas spring
 ** with 2x external gas springs

COLLECTION ELEMENTS SYSTEM 75-CB

MATERIAL:

Pipe and tip: Polypropylene (PP) white

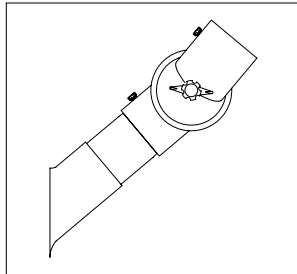

SUCTION TIP FOR SUCTION ARM

Length (mm)	Item No.
250	10990

MATERIAL:

Round hood: Aluminium white (powder-coated)

Flange: Polypropylene (PP) white

Pipe sockets: Polypropylene (PP) white

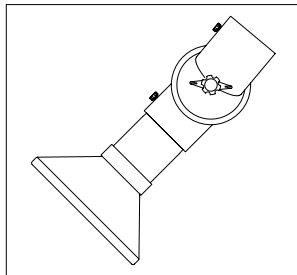

SUCTION HOOD FOR SUCTION ARM

Ø (mm)	Item No.
200	13150

MATERIAL:

Round hood: Polypropylene (PP) white

Flange: Polypropylene (PP) white

Pipe sockets: Polypropylene (PP) white

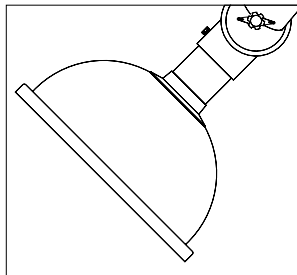

SUCTION HOOD FOR SUCTION ARM

Ø (mm)	Item No.
385	10899

COLLECTION ELEMENTS SYSTEM 75-CB

MATERIAL:

Square hood: Polypropylene (PP) white

Flange: Polypropylene (PP) white

Pipe sockets: Polypropylene (PP) white

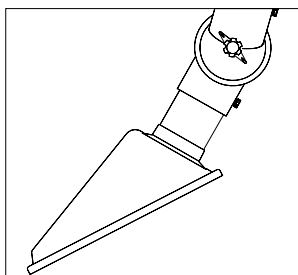

SUCTION HOOD FOR SUCTION ARM

Dimensions (mm)	Item No.
420x320	15488

MATERIAL:

Flat screen: Polypropylene (PP) white

Flange: Polypropylene (PP) white

Pipe sockets: Polypropylene (PP) white

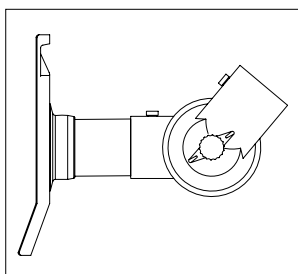

FLAT SCREEN FOR SUCTION ARM

Dimensions (mm)	Item No.
330x240	15489

HOLDER AND BASE BOX SYSTEM 75-CB

MATERIAL:

Holder: Steel white (powder-coated)

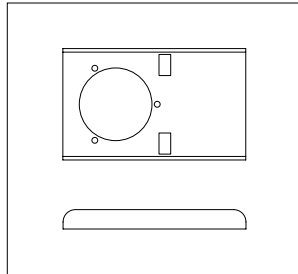

DESK HOLDER

Use	Item No.
System 75	10202

MATERIAL:

Bracket: Steel white (powder-coated)

Flange: Polypropylene (PP) white

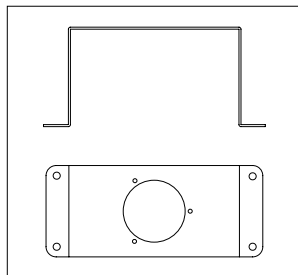

DESK BRACKET

Use	Item No.
System 75	12017

MATERIAL:

Bracket: Steel white (powder-coated)

Connection: Ø 80 mm

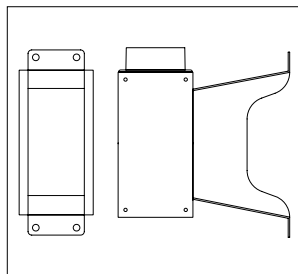

WALL HOLDER

Use	Item No.
System 75	14671

HOLDER AND BASE BOX SYSTEM 75-CB

MATERIAL:

Bracket: Steel white (powder-coated)

Lateral connection: Ø 80 mm

Connection, top: max. Ø 100 mm

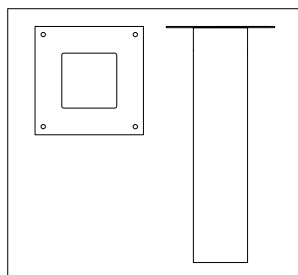

CEILING HOLDER

Length (mm)	Weight (kg)	Item No.
250	2.0	15000*
500	3.0	10207
750	3.8	10208
1000	4.5	10215
1250	5.4	15443
1500	6.1	15444
1750	7.1	15445
2000	7.9	15446

* only top connection, max Ø 100 mm

MATERIAL:

Holder: Steel white (powder-coated)

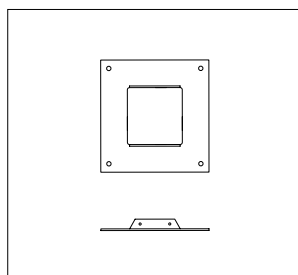
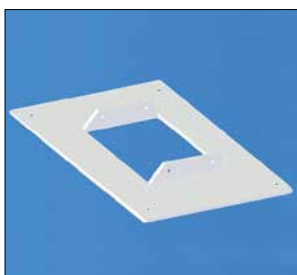

AMPLIFIER HOLDER FOR BASE BOX L ≥ 2000 mm

Dimensions (mm)	Item No.
Internal: 100x100 External: 200x200	15581

MATERIAL:

Frame: Polystyrene (PS) white

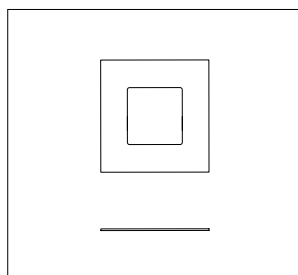
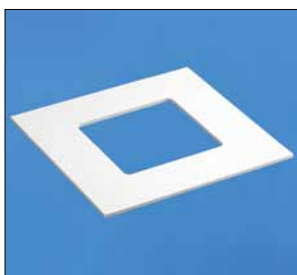

DECORATION FLANGE / COVER FRAME FOR BASE BOX

Dimensions (mm)	Item No.
Internal: 100x100 External: 200x200	15577

MATERIAL:

Socket: Polypropylene (PP) white

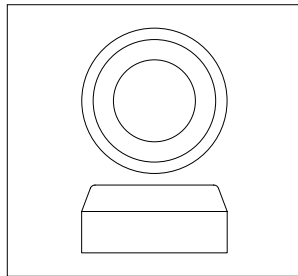

REDUCING SOCKET

Ø (mm)	Item No.
80-75	14180
100-75	10346

MATERIAL:

Bracket: Steel white (powder-coated)

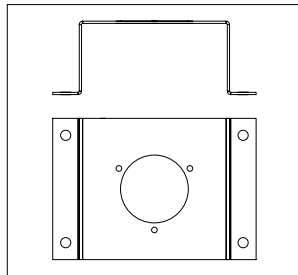

ADAPTION SET FOR SUCTION ARM

Comprised of: 1x bracket, 1x flange

Use	Item No.
LN 230, GL230	13192
LN 260, LN 265, GL 265, GL 400	13195
BF Series	See BF Series catalogue for all available suction arm variants



PEOPLE / ENVIRONMENT / MACHINERY // TRIPLE PROTECTION

ALSIDENT® SYSTEM 100 is suited for air volumes between 140-400 m³/h (80-235 CFM).

Depending on material version, ALSIDENT® SYSTEM 100 is very applicable in trades such as laboratories, hospitals, chemical industries, and pharmaceutical industries and the food industry, universities and machine shops where a large capacity is needed.

Adjusted to the work conditions

The ALSIDENT® SYSTEM 100 suction arms are quickly mounted with standard brackets for table, wall or ceiling.

The standard ALSIDENT® SYSTEM 100 is available in various types that are complementary to each other with reaches up to 2630 mm (103.54"). Therefore it is possible to choose an extraction arm applicable for each work situation.

Material versions

ALSIDENT® SYSTEM 100 is available in three material versions – aluminium (AL), antistatic (AS) and chemical resistant (CR). The choice of material version depends on each work process and type of pollution.

The suction arms are fitted with throttle valves to regulate the volume flow.

Aluminium (AL) – For most applications

ALSIDENT® SYSTEM 100 AL is used in environments with no special demands for chemical resistance or conductivity. The ALSIDENT® SYSTEM 100 AL suction arms consist of aluminium tubes and joints of white Polypropylene (PP).

Antistatic (AS) – for ESD or EX-environments

ALSIDENT® SYSTEM 100 AS suction arms are used in environments with special demands for conductivity, e.g. in sensitive ESD-environments or in environments with explosive atmosphere. The suction arms are delivered with earthing wire. The tubes and joints of the antistatic version are made of black conductive Poly-propylene (PP).

ALSIDENT® SYSTEM 100 AS has been tested and approved for use in ESD-environments according to IEC 61340-5-1.

ALSIDENT® SYSTEM 100 has also been approved for use in explosive areas and is marked:

EX II 1 GD

Chemical Resistant (PP) – for aggressive areas

The ALSIDENT® SYSTEM 100 Chemical Resistant (PP) suction arms are used in work areas with special requirements for chemical resistance because of the type of pollution, e.g. chemical fumes. The tubes and joints of this material version are made of white Polypropylene (PP).

ORDER DATA SYSTEM 100-AL

MATERIAL:

Pipe: Aluminium (anodized)

Joint(s) and flange: Polypropylene (PP) white

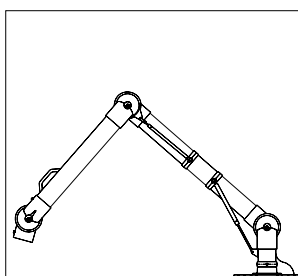
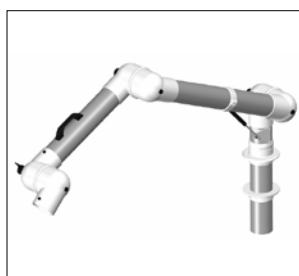
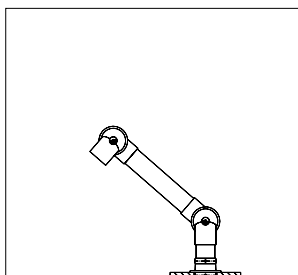
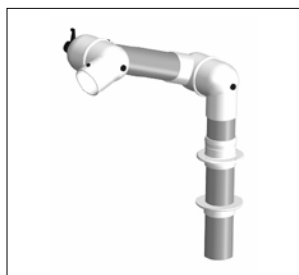

SUCTION ARMS Ø 100 mm

Table mounting (TM), 2 joints

Range (mm)	Weight (kg)	Item No.
550	3.5	11277

Table mounting (TM), 3 joints

Range (mm)	Weight (kg)	Item No.
850	4.5	11272
1000	5.0	11269
1200	5.5	11265
1550*	6.5	11262
1900**	7.0	11266

* with 1x external gas spring and handle on the B-pipe
 ** with 2x external gas springs and handle on the B-pipe

MATERIAL:

Pipe: Aluminium (anodized)

Joint(s) and flange: Polypropylene (PP) white

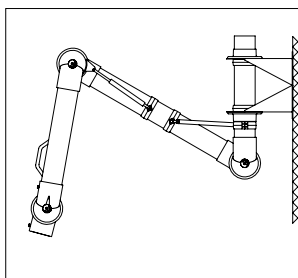
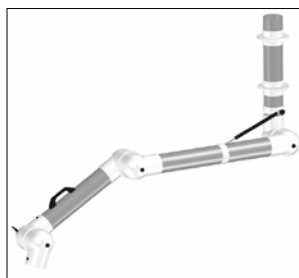
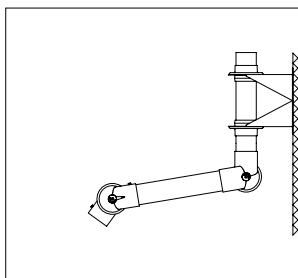
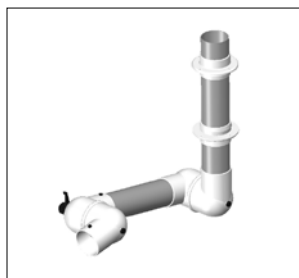

SUCTION ARMS Ø 100 mm

Wall mounting (WM), 2 joints

Range (mm)	Weight (kg)	Item No.
550	4.0	Upon request

Wall mounting (WM), 3 joints

Range (mm)	Weight (kg)	Item No.
850	5.0	11268
1000	5.5	11267
1200	6.0	11264
1550*	7.0	11260
1900**	7.5	10956
2400**	8.5	10999

* with 1x external gas spring and handle on the B-pipe
 ** with 2x external gas springs and handle on the B-pipe

MATERIAL:

Pipe: Aluminium (anodized)

Joint(s) and flange: Polypropylene (PP) white

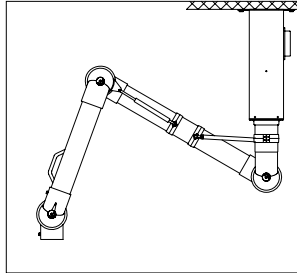
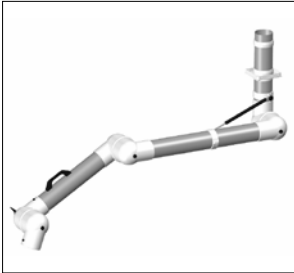

SUCTION ARM Ø 100 mm

Ceiling mounting (CM), 3 joints

Range (mm)	Weight (kg)	Item No.
1000	5.5	11258
1200	6.0	11253
1550*	7.0	11250
1900**	7.5	11247
2400**	8.5	11273

* with 1x external gas spring and handle on the B-pipe

** with 2x external gas springs and handle on the B-pipe

COLLECTION ELEMENTS SYSTEM 100-AL

MATERIAL:

Round hood: Aluminium white (powder-coated)

Flange: Aluminium white (powder-coated)

Pipe sockets: Aluminium (anodized)

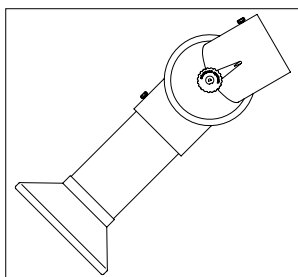

SUCTION HOOD FOR SUCTION ARM

Ø (mm)	Item No.
200	10960

MATERIAL:

Round hood: Aluminium (anodized)

Flange: Aluminium (anodized)

Pipe sockets: Aluminium (anodized)

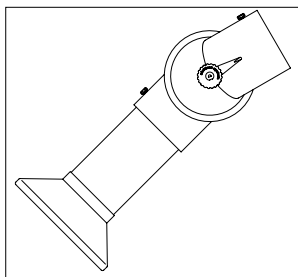

SUCTION HOOD FOR SUCTION ARM

Ø (mm)	Item No.
200	15755

MATERIAL:

Round hood: Aluminium white (powder-coated)

Flange: Polypropylene (PP) white

Pipe sockets: Aluminium (anodized)

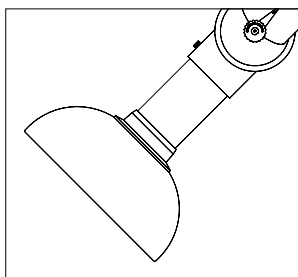

SUCTION HOOD FOR SUCTION ARM

Ø (mm)	Item No.
350	15756

COLLECTION ELEMENTS SYSTEM 100-AL

MATERIAL:

Round hood: Aluminium (chromated)

Flange: Polypropylene (PP) white

Pipe sockets: Aluminium (anodized)

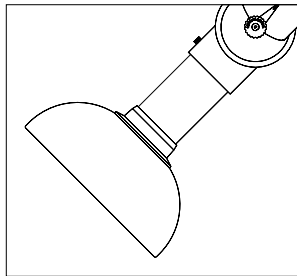

SUCTION HOOD FOR SUCTION ARM

Ø (mm)	Item No.
350	11215

MATERIAL:

Round hood: PETG transparent

Flange: Polypropylene (PP) white

Pipe sockets: Aluminium (anodized)

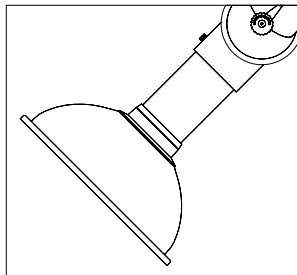

SUCTION HOOD FOR SUCTION ARM

Ø (mm)	Item No.
385	14547

MATERIAL:

Round hood: PETG transparent

Flange: Polypropylene (PP)

Pipe sockets: Aluminium (anodized)

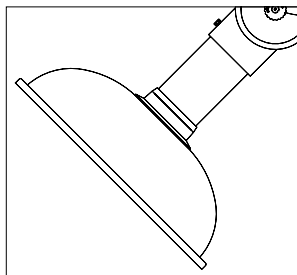

SUCTION HOOD FOR SUCTION ARM

Ø (mm)	Item No.
500	11074

COLLECTION ELEMENTS SYSTEM 100-AL

MATERIAL:

Flat screen: PETG transparent

Flange: Polypropylene (PP) white

Pipe sockets: Aluminium (anodized)

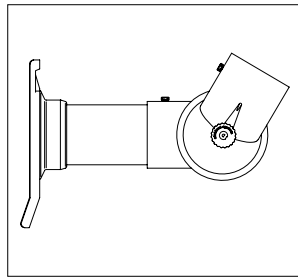

FLAT SCREEN FOR SUCTION ARM

Dimensions (mm)	Item No.
420x280	15336

HOLDER AND BASE BOX SYSTEM 100-AL

MATERIAL:

Bracket: Steel white (powder-coated)

Flange: Polypropylene (PP) white

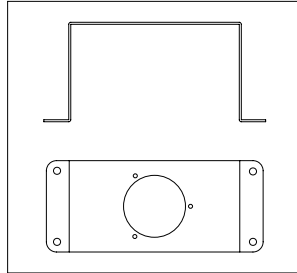

DESK BRACKET

Use	Item No.
System 100	11427

MATERIAL:

Bracket: Steel white* (powder-coated)

Connection: Ø 100 mm

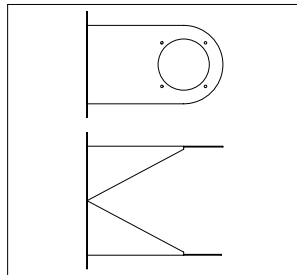

WALL HOLDER FOR SUCTION ARM (2-part)

Vertical/pendant mounting

Use	Item No.
System 100	10937

** upon request, also available in different colours or stainless steel (black, see System 100-AS)*

MATERIAL:

Bracket: Steel white* (powder-coated)

Lateral connection: Ø 125 mm

Connection, top: max. Ø 125 mm

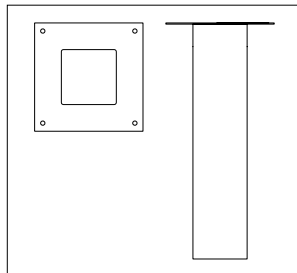

CEILING HOLDER

Length (mm)	Weight (kg)	Item No.
500	4.0	11314
750	5.5	15757
1000	6.5	11311
1500	9.0	14669
1750	10.5	14941
2000	11.5	15758

** also available in black (see SYSTEM 100-AS)*

HOLDER AND BASE BOX SYSTEM 100-AL

MATERIAL:

Holder: Steel white (powder-coated)

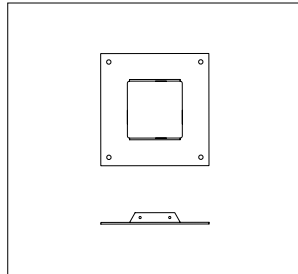
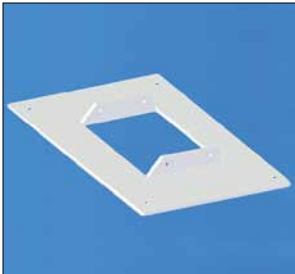

AMPLIFIER HOLDER FOR BASE BOX $L \geq 2000$ mm

Dimensions (mm)	Item No.
Internal: 150x150 External: 250x250	15582

MATERIAL:

Frame: Polystyrene (PS) white

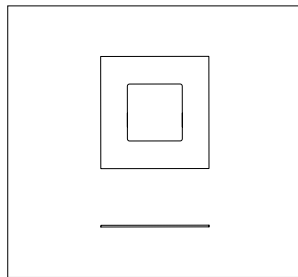
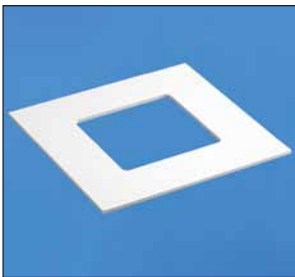

DECORATION FLANGE / COVER FRAME FOR BASE BOX

Dimensions (mm)	Item No.
Internal: 150x150 External: 250x250	15578

FURTHER ACCESSORIES SYSTEM 100-AL

MATERIAL:

Socket: Polypropylene (PP) white*

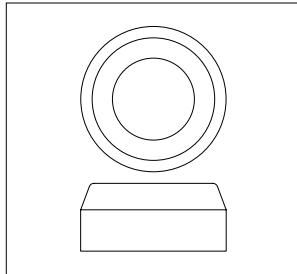

REDUCING SOCKET

Ø (mm)	Item No.
125-100	11241

* also available in black (see SYSTEM 100-AS)

MATERIAL:

Bracket: Steel white (powder-coated)

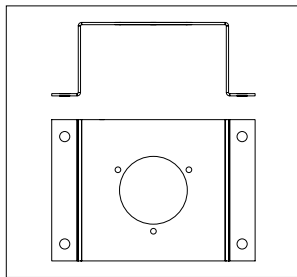

ADAPTION SET FOR SUCTION ARM

Comprised of: 1x bracket, 1x flange

Use	Item No.
LN 260, LN 265, GL 265, GL 400	13196
BF Series	See BF Series catalogue for all available suction arm variants

ORDER DATA SYSTEM 100-AS

MATERIAL:

Pipe: Polypropylene (PP) conductive, black

Joint(s) and flange: Polypropylene (PP) conductive, black

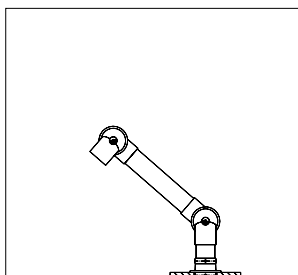

SUCTION ARMS Ø 100 mm

Table mounting (TM), 2 joints

Range (mm)	Weight (kg)	Item No.
550	3.5	11300

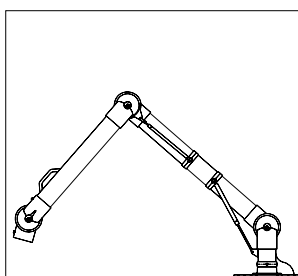

Table mounting (TM), 3 joints

Range (mm)	Weight (kg)	Item No.
850	4.5	11298
1000	5.0	11293
1200	5.5	11288
1550*	6.5	11286
1900**	7.0	11282

* with 1x external gas spring and handle on the B-pipe
 ** with 2x external gas springs and handle on the B-pipe

MATERIAL:

Pipe: Polypropylene (PP) conductive, black

Joint(s) and flange: Polypropylene (PP) conductive, black

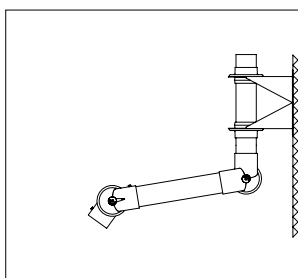

SUCTION ARMS Ø 100 mm

Wall mounting (WM), 2 joints

Range (mm)	Weight (kg)	Item No.
550	4.0	15759

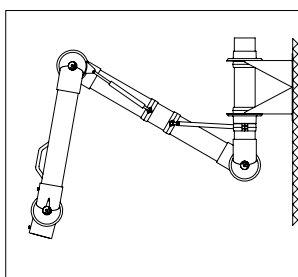

Wall mounting (WM), 3 joints

Range (mm)	Weight (kg)	Item No.
850	5.0	11289
1000	5.5	11284
1200	6.0	11280
1550*	7.0	11276
1900**	7.5	10989
2400**	8.5	10992

* with 1x external gas spring and handle on the B-pipe
 ** with 2x external gas springs and handle on the B-pipe

MATERIAL:

Pipe: Polypropylene (PP) conductive, black

Joint(s) and flange: Polypropylene (PP) conductive, black

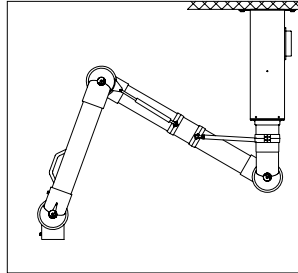

SUCTION ARM Ø 100 mm

Ceiling mounting (CM), 3 joints

Range (mm)	Weight (kg)	Item No.
1000	5.5	11308
1200	6.0	11306
1550*	7.0	11302
1900**	7.5	11294
2400**	8.5	11296

* with 1x external gas spring and handle on the B-pipe

** with 2x external gas springs and handle on the B-pipe

COLLECTION ELEMENTS SYSTEM 100-AS

MATERIAL:

Round hood: Aluminium (chromated)

Flange: Polypropylene (PP) conductive, black

Pipe sockets: Polypropylene (PP) conductive, black

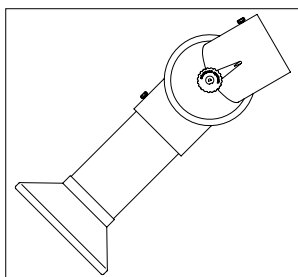

SUCTION HOOD FOR SUCTION ARM

Ø (mm)	Item No.
200	11107

MATERIAL:

Round hood: Aluminium (chromated)

Flange: Polypropylene (PP) conductive, black

Pipe sockets: Polypropylene (PP) conductive, black

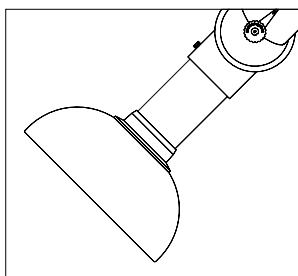

SUCTION HOOD FOR SUCTION ARM

Ø (mm)	Item No.
350	11410

MATERIAL:

Round hood: Polypropylene (PP) conductive, black

Flange: Polypropylene (PP) conductive, black

Pipe sockets: Polypropylene (PP) conductive, black

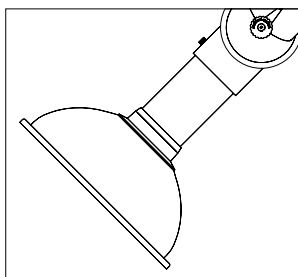

SUCTION HOOD FOR SUCTION ARM

Ø (mm)	Item No.
385	15130

COLLECTION ELEMENTS SYSTEM 100-AS

MATERIAL:

Round hood: Polypropylene (PP) conductive, black

Flange: Polypropylene (PP) conductive, black

Pipe sockets: Polypropylene (PP) conductive, black

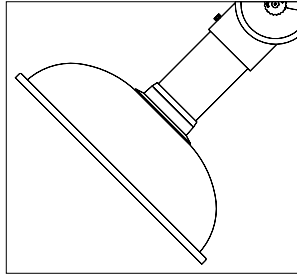

SUCTION HOOD FOR SUCTION ARM

Ø (mm)	Item No.
500	12519

MATERIAL:

Flat screen: Polypropylene (PP) conductive, black

Flange: Polypropylene (PP) conductive, black

Pipe sockets: Polypropylene (PP) conductive, black

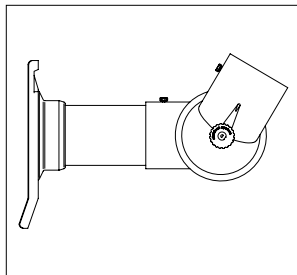

FLAT SCREEN FOR SUCTION ARM

Dimensions (mm)	Item No.
420x280	13321

HOLDER AND BASE BOX SYSTEM 100-AS

MATERIAL:

Bracket: Steel white (powder-coated)

Flange: Polypropylene (PP) white

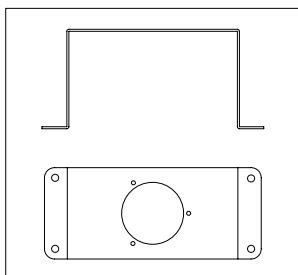

DESK BRACKET

Use	Item No.
System 100	11427

MATERIAL:

Bracket: Steel black* (powder-coated)

Connection: Ø 100 mm

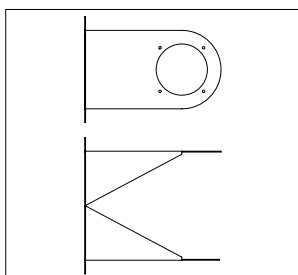

WALL HOLDER FOR SUCTION ARM (2-part)

Vertical/pendant mounting

Use	Item No.
System 100	14604

** upon request, also available in different colours or in stainless steel*

MATERIAL:

Bracket: Steel black (powder-coated)

Lateral connection: Ø 125 mm

Connection, top: max. Ø 125 mm

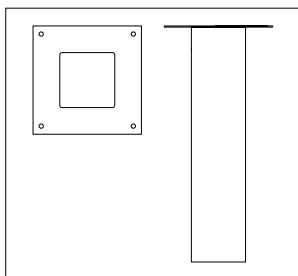

CEILING HOLDER

Length (mm)	Weight (kg)	Item No.
500	4.0	15761
750	5.5	15760
1000	6.5	15132

FURTHER ACCESSORIES SYSTEM 100-AS

MATERIAL:

Socket: Polypropylene (PP) black

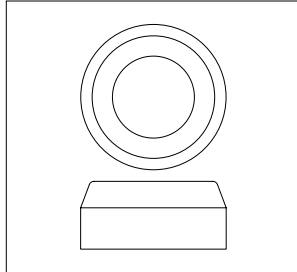

REDUCING SOCKET

Ø (mm)	Item No.
125-100	15405

MATERIAL:

Bracket: Steel white (powder-coated)

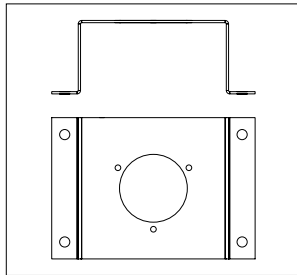

ADAPTION SET FOR SUCTION ARM

Comprised of: 1x bracket, 1x flange

Use	Item No.
LN 260, LN 265, LN 600, GL 265, GL 400, FP 200	13196
BF Series	See BF Series catalogue for all available suction arm variants

ORDER DATA SYSTEM 100-CB

MATERIAL:

Pipe: Polypropylene (PP) white

Joint(s) and flange: Polypropylene (PP) white

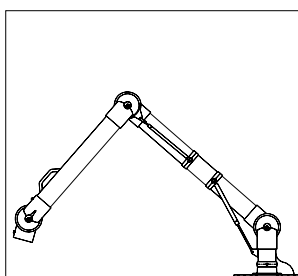
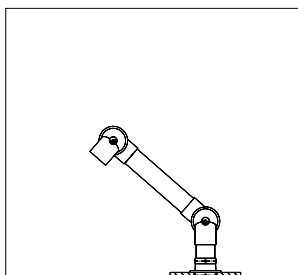

SUCTION ARMS Ø 100 mm

Table mounting (TM), 2 joints

Range (mm)	Weight (kg)	Item No.
550	3.0	11307

Table mounting (TM), 3 joints

Range (mm)	Weight (kg)	Item No.
850	4.0	11303
1000	4.5	11299
1200	5.0	11295
1550*	6.0	11291
1900**	6.5	11287

* with 1x external gas spring and handle on the B-pipe
 ** with 2x external gas springs and handle on the B-pipe

MATERIAL:

Pipe: Polypropylene (PP) white

Joint(s) and flange: Polypropylene (PP) white

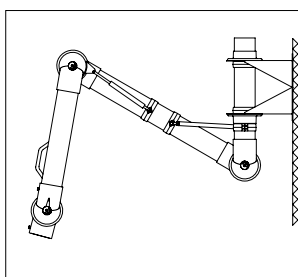
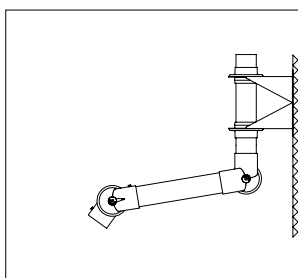

SUCTION ARMS Ø 100 mm

Wall mounting (WM), 2 joints

Range (mm)	Weight (kg)	Item No.
550	3.5	15762

Wall mounting (WM), 3 joints

Range (mm)	Weight (kg)	Item No.
850	4.5	11292
1000	5.0	11285
1200	5.5	11290
1550*	6.5	11281
1900**	7.0	10985
2400**	8.0	10996

* with 1x external gas spring and handle on the B-pipe
 ** with 2x external gas springs and handle on the B-pipe

MATERIAL:

Pipe: Polypropylene (PP) white

Joint(s) and flange: Polypropylene (PP) white

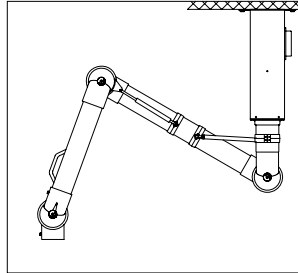

SUCTION ARM Ø 100 mm

Ceiling mounting (CM), 3 joints

Range (mm)	Weight (kg)	Item No.
1000	5.0	11279
1200	5.5	11309
1550*	6.5	11304
1900**	7.0	11301
2400**	8.0	11297

* with 1x external gas spring and handle on the B-pipe

** with 2x external gas springs and handle on the B-pipe

COLLECTION ELEMENTS SYSTEM 100-CB

MATERIAL:

Round hood: Aluminium white (powder-coated)

Flange: Aluminium white (powder-coated)

Pipe sockets: Polypropylene (PP) white

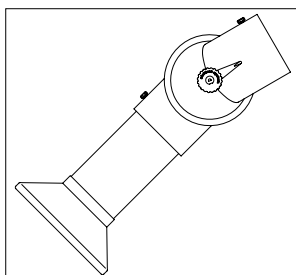

SUCTION HOOD FOR SUCTION ARM

Ø (mm)	Item No.
200	11305

MATERIAL:

Round hood: Polypropylene (PP) white

Flange: Polypropylene (PP) white

Pipe sockets: Polypropylene (PP) white

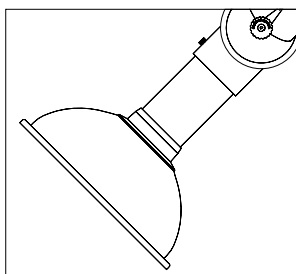

SUCTION HOOD FOR SUCTION ARM

Ø (mm)	Item No.
385	14993

MATERIAL:

Round hood: Polypropylene (PP) white, semi-transparent

Flange: Polypropylene (PP) white

Pipe sockets: Polypropylene (PP) white

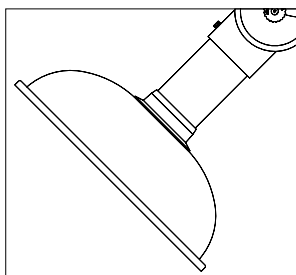

SUCTION HOOD FOR SUCTION ARM

Ø (mm)	Item No.
500	11138

COLLECTION ELEMENTS SYSTEM 100-CB

MATERIAL:

Flat screen: Polypropylene (PP) white

Flange: Polypropylene (PP) white

Pipe sockets: Polypropylene (PP) white

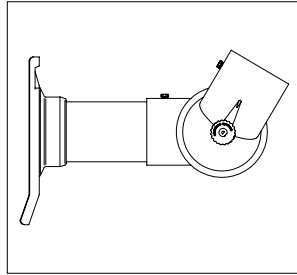

FLAT SCREEN FOR SUCTION ARM

Dimensions (mm)	Item No.
420x280	15763

HOLDER AND BASE BOX SYSTEM 100-CB

MATERIAL:

Bracket: Steel white (powder-coated)

Flange: Polypropylene (PP) white

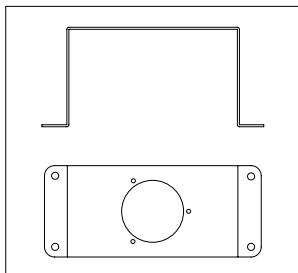
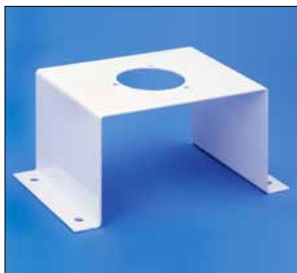

DESK BRACKET

Use	Item No.
System 100	11427

MATERIAL:

Bracket: Steel white (powder-coated)

Connection: Ø 100 mm

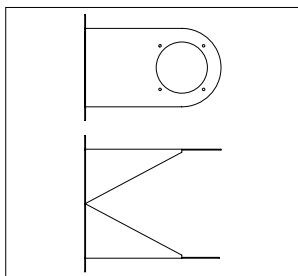

WALL HOLDER FOR SUCTION ARM (2-part)

Vertical/pendant mounting

Use	Item No.
System 100	10937

MATERIAL:

Bracket: Steel white (powder-coated)

Lateral connection: Ø 125 mm

Connection, top: max. Ø 125 mm

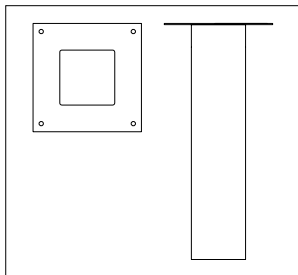

CEILING HOLDER

Length (mm)	Weight (kg)	Item No.
500	4.0	11314
750	5.5	15757
1000	6.5	11311
1500	9.0	14669
1750	10.5	14941
2000	11.5	15758

HOLDER AND BASE BOX SYSTEM 100-CB

MATERIAL:

Holder: Steel white (powder-coated)

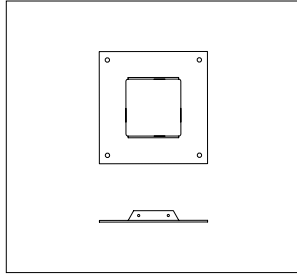
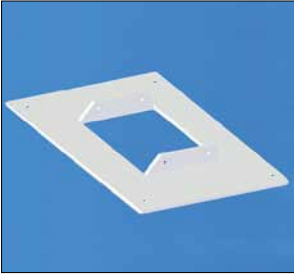

AMPLIFIER HOLDER FOR BASE BOX L ≥ 2000 mm

Dimensions (mm)	Item No.
Internal: 150x150 External: 250x250	15582

MATERIAL:

Frame: Polystyrene (PS) white

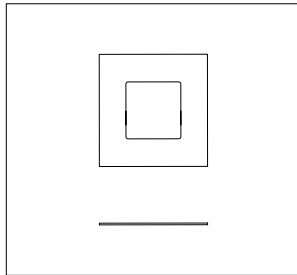
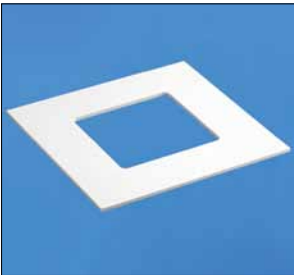

DECORATION FLANGE / COVER FRAME FOR BASE BOX

Dimensions (mm)	Item No.
Internal: 150x150 External: 250x250	15578

FURTHER ACCESSORIES SYSTEM 100-CB

MATERIAL:

Socket: Polypropylene (PP) white

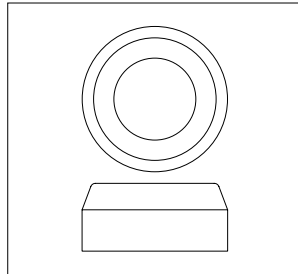

REDUCING SOCKET

Ø (mm)	Item No.
125-100	11241

MATERIAL:

Bracket: Steel white (powder-coated)

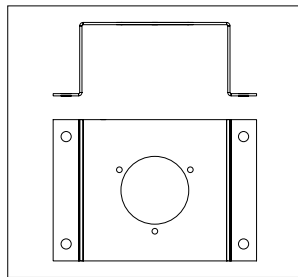

ADAPTION SET FOR SUCTION ARM

Comprised of: 1x bracket, 1x flange

Use	Item No.
LN 260, LN 265, LN 600, GL 265, GL 400, FP 200	13196
BF Series	See BF Series catalogue for all available suction arm variants



PEOPLE / ENVIRONMENT / MACHINERY // TRIPLE PROTECTION

ALSIDENT® SYSTEM 25 work cabinets are designed for air volumes between 117 - 850 m³/h (68-500 CFM).

ALSIDENT® SYSTEM 25 is very applicable for working processes such as: weighing and trans-filling of powders, mixing of chemicals, hair dye and fluids for permanent waving, small grinding jobs, measuring and analyzing operations, using solvents for cleaning of small parts such as printed circuits, gluing etc. The work cabinets are therefore used at various work places such as hospitals, laboratories, hairdressers', dentists and dental laboratories.

ALSIDENT® SYSTEM 25

- three types of work cabinets

ALSIDENT® SYSTEM 25 offers 3 types of work cabinets in various sizes and designs. The air volume is decided by the size of the opening.

The recommended air volumes of the standard work cabinets are stated on the insert.

Type 1

– three sizes, three air volumes

Type 1 is equipped with a transparent vacuum moulded PETG top with a window of safety glass allowing a good view of the working process. The transparent sides of PETG are assembled with aluminium supports in the corners. This type is available with sides in three different heights of approximately 200, 500 or 750 mm (8", 20" or 30"). The higher cabinets have a bigger opening and therefore a larger air volume.

Cabinet Type 1 is delivered unassembled and with loose screws in order to reduce the freight costs.

Type 2

– moulded work cabinet with small opening

Type 2 is a vacuum moulded cabinet of transparent PETG with a window of safety glass allowing a good view of the working process.

The broad cabinet with a small opening has lots of space for hands and arms. This work cabinet is therefore suited for small tasks such as grinding or cleaning.

Cabinet Type 2 is also available in a semi-transparent (opal white) version.

Customized solutions

– short delivery time

In addition to the standard products, ALSIDENT® SYSTEM 25 also offers special solutions. The customized cabinets in various sizes can be equipped with sliding doors, side-hung or tophung doors, slanting opening or built-in suction arm.

The technical department will send a drawing of the customized cabinet to the customer for approval before starting the production.

The delivery time is short – both for standard products and customized solutions.

ORDER DATA SYSTEM 25 TYPE 1

MATERIAL:

Upper part: PETG transparent, cast

Sides: PETG transparent

Windows: Tempered glass

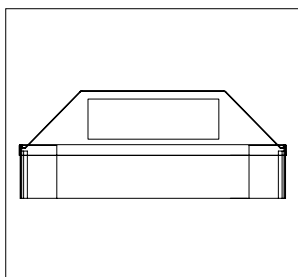

Corner and edge profile: Aluminium (anodized)

Clamping profile: Rubber

Cabinet flange: Polypropylene (PP)

Cabinet HxWxD: 410 x 1000 x 600 mm
 Side height: 200 mm
 Opening: 720 x 160 mm
 Air volume: 220 m³/h

Type 1 - small

white*	red*
Item No.	Item No.
10232	15534

* protective corners on the window and, potentially, the flange

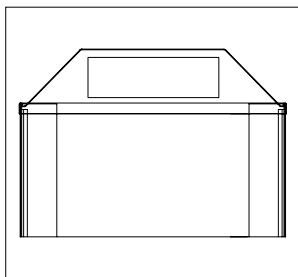

Cabinet HxWxD: 710 x 1000 x 600 mm
 Side height: 500 mm
 Opening: 715 x 460 mm
 Air volume: 550 m³/h

Type 1 - medium

white*	red*
Item No.	Item No.
10238	15535

* protective corners on the window and, potentially, the flange

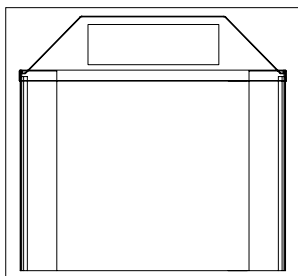

Cabinet HxWxD: 960 x 1000 x 600 mm
 Side height: 750 mm
 Opening: 715 x 710 mm
 Air volume: 850 m³/h

Type 1 - large

white*	red*
Item No.	Item No.
10214	15536

* protective corners on the window and, potentially, the flange

MATERIAL:

Flange: Polypropylene (PP)

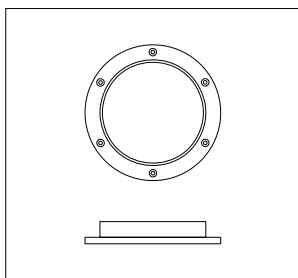

Connection flange

Ø (mm)	white	red
	Item No.	Item No.
50	10222	15539
75	10229	15540
80	10326	10350
100	10235	10233
125	10356	15541
160	10212	15765

ORDER DATA SYSTEM 25 TYPE 2

MATERIAL:

Cabinet: PETG transparent, cast

Windows: Tempered glass

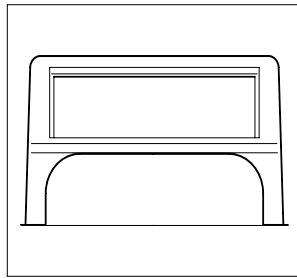

Clamping profile: Rubber

Cabinet flange: Polypropylene (PP)

Cabinet HxWxD: 350 x 635 x 480 mm
 Opening: 515 x 145 mm
 Air volume: 117 m³/h

Type 2

white*	red*
Item No.	Item No.
15537	10221

* protective corners on the window and, potentially, the flange

MATERIAL:

Cabinet: PETG white, cast

Windows: Tempered glass

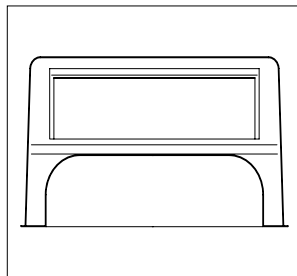

Clamping profile: Rubber

Cabinet flange: Polypropylene (PP)

Cabinet HxWxD: 350 x 635 x 480 mm
 Opening: 515 x 145 mm
 Air volume: 117 m³/h

Type 2 - opal

white*	red*
Item No.	Item No.
10225	15538

* protective corners on the window and, potentially, the flange

MATERIAL:

Flange: Polypropylene (PP)

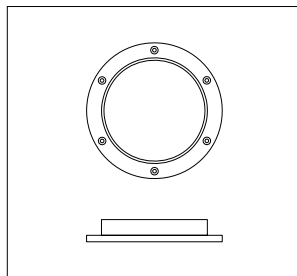

Connection flange

Ø (mm)	white	red
	Item No.	Item No.
50	10222	15539
75	10229	15540
80	10326	10350
100	10235	10233
125	10356	15541
160	10212	15765

ORDER DATA SYSTEM 25 TYPE 3

MATERIAL:

Upper part: PETG transparent, cast

Sides: Steel white (powder-coated)

Joint and flange internal/external width:

Polypropylene (PP)

Pipe sockets: Aluminium (anodized)

O-ring: Polyethylene (PE)

Throttle valve: Polyethylene (PE)

Thumb screw: Polypropylene (PP)

Threaded pin: Steel stainless, acid-proof

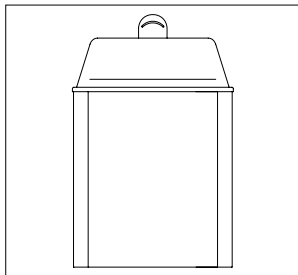

Cabinet HxWxD: 515 x 420 x 320 mm

Side height: 400 mm

Opening: 435 x 395 mm

Air volume: 200 m³/h

Type 3

Item No.

12487

SPECIAL SUCTION ARMS SYSTEM 160

In addition to the Alsident product range, TBH also offers specific suction arms for source extraction in the field of welding fume as well as for large-scale extraction tasks. Further variants are possible if required. Please contact your TBH sales team in this regard.



Suction arm System 160

Cross-section (mm)	A (mm)	B (mm)	Item No.
160	500	500	15493
160	1000	1000	15494
160	1500	1500	15495

The suction arms are prepared for wall mounting. They can be merged directly with fixed pipework at their connection.

- Very large movement pattern - perpendicular
- Can rotate 360° to relieve the hose
- Includes mounting bracket for wall mounting
- Construction with external rod system
- Flow-optimised funnel with shut-off flap

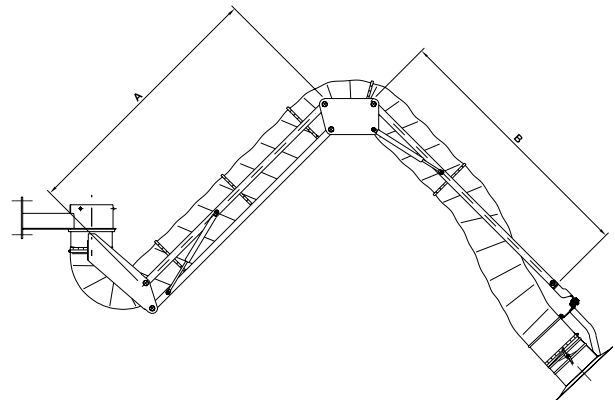
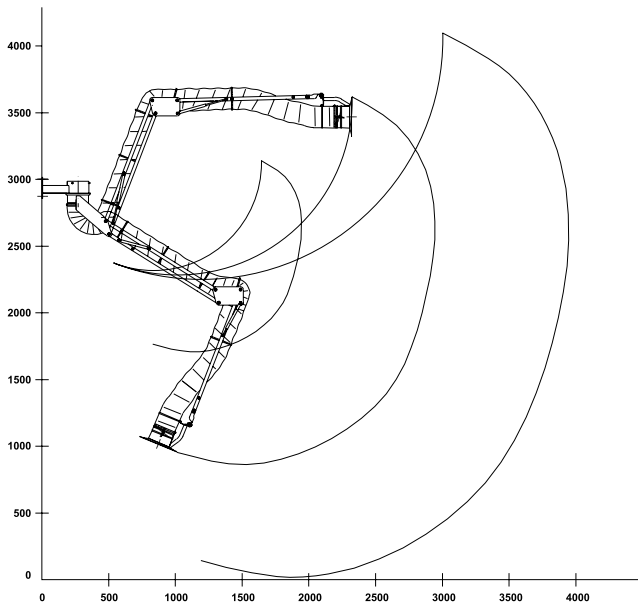

SPECIAL SUCTION ARMS SYSTEM 160



Suction arm System 160

Cross-section (mm)	A (mm)	B (mm)	Item No.
160	500	500	15772
160	1000	1000	15773
160	1500	1500	15774

The suction arms are designed for desk / wall mounting or for installation in an extraction and filtration unit such as those of the LN600 Series or FP/FPV 200 Series. They can be merged directly with a flexible hose connection at their connection.

- Includes mounting bracket for desk/wall mounting or for installation in an extraction and filtration unit
- Construction with external rod system
- Flow-optimised funnel with shut-off flap

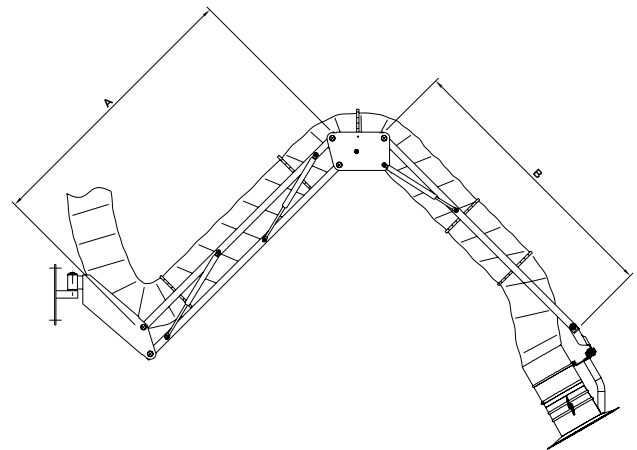
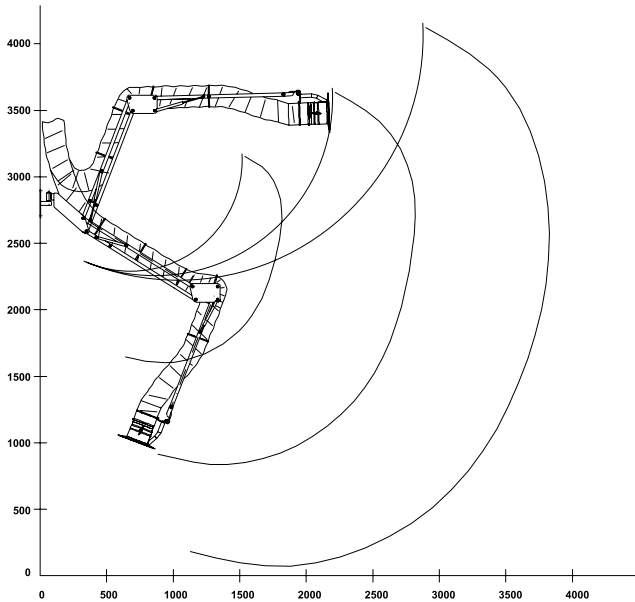



PEOPLE / ENVIRONMENT / MACHINERY // TRIPLE PROTECTION

Here you can find the right hose for your extraction and filtration unit. Please note that, depending on the type of unit, choosing the right hose is very important for the performance and effectiveness of the unit. In general, the diameter of the hose should be chosen according to the following criteria:

Differential pressure loss

Resistance which the hose generates at the extraction unit (leads to weaker performance at the point of extraction) - the differential pressure should be as low as possible i.e. choose as large a cross-section as possible.

Air speed

At the point of extraction (optimal collection) and in the hose (prevents heavy particles from being deposited in, and subsequently blocking, the hose) - the requisite air speed is dependent on the size of the particles which are created in the process (e.g. laser smoke: 0.2-0.4 m/s).

Please contact your TBH sales team in this regard.

MATERIAL:

Hose: PVC

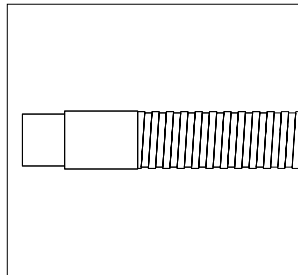

HOSE SET WITH CONNECTION SLEEVE

suitable for all standard applications

DN (mm)	Length (m)	Item No.
50	2.5	10008
	5.0	10010

MATERIAL:

Hose: PVC

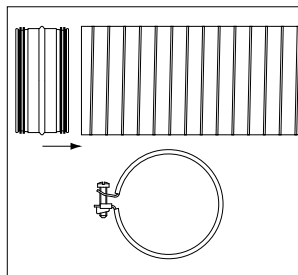

HOSE SET WITH NIPPLE AND HOSE CLIPS

suitable for all standard applications

DN (mm)	Length (m)	Item No.
80	2.5	13179*
	2.5	13729**
	5.0	13180*
	5.0	14600**
	10.0	13197
	10.0	15322**
100	2.5	13181
	5.0	13182
	10.0	13198
125	2.5	13183
	5.0	13184
	10.0	13199
160	2.5	13185
	5.0	13186
	10.0	13200

* for LN 230

** for LN 260, 265 (with reduction DN 100 to DN 80)

HOSES

MATERIAL:

Hose: Polyurethane (PU) highly flexible, can be shortened

Property: Amplification by spring steel spirals, internally/externally corrugated

Temperature range: -40°C to +90°C

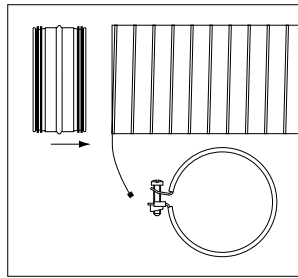

HOSE SET - CHEMICALLY RESISTANT

suitable for applications with aggressive media

Comprised of: 1x hose, 1x nipple system safe or reduction DN100 to DN80, 2x hose clips

DN (mm)	Length (m)	Item No.
80	2.5	15496*
	2.5	15497**
	5.0	15498*
	5.0	15499**
	10.0	15500*
	10.0	15501**
100	2.5	15502
	5.0	15503
	10.0	15504
125	2.5	15505
	5.0	15506
	10.0	15507

* for LN230, GL230 and FP150

** for LN260, LN265, GL265, GL400 (with reduction DN100 to DN80)

We are happy to provide further diameters on request - please contact TBH sales.

MATERIAL:

Hose: Polyurethane (PU), discharge conductive for use in ATEX range, flexible

Property: Amplification by spring steel spirals, internally/externally corrugated

Temperature range: -40°C to +90°C

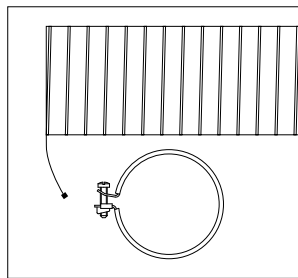

HOSE SET - ANTI-STATIC

for applications in ESD / ATEX range -
with earth connection

Comprised of: 1x hose, 2x wire hose clamp

DN (mm)	Length (m)	Item No.
63	2.5	15086
	5.0	15093
80	2.5	15087
	5.0	15094
100	2.5	15088
	5.0	15095
125	2.5	15089
	5.0	15096
160	2.5	15090
	5.0	15097
200	2.5	15091
	5.0	15098
250	2.5	15092
	5.0	15099

MATERIAL:

Hose: Polyurethane (PU), discharge conductive for use in ATEX range, flexible

Property: Amplification by spring steel spirals, internally/externally corrugated

Temperature range: -40°C to +90°C

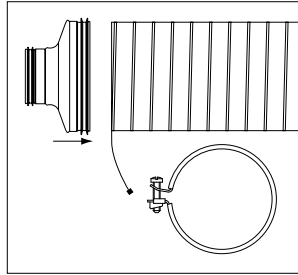
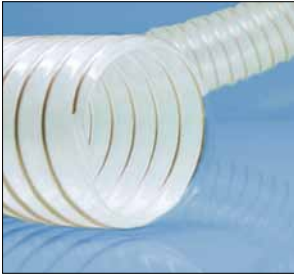

HOSE SET - FP ATEX

specifically for FP 150 ATEX - with earth connection

Comprised of:

1x hose, 2x wire hose clamp, 1x reduction DN 80

DN (mm)	Length (m)	Item No.
50	2.5	15372
	5.0	15373
63	2.5	15374
	5.0	15375
	10.0	15376

MATERIAL:

Hose: Polyurethane (PU), discharge conductive for use in ATEX range, flexible

Property: Amplification by spring steel spirals, internally/externally corrugated

Temperature range: -40°C to +90°C

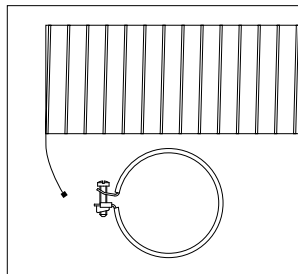

HOSE SET - FP ATEX

specifically for FP 150 ATEX - with earth connection

Comprised of: 1x hose, 2x wire hose clamp

DN (mm)	Length (m)	Item No.
80	2.5	15087
	5.0	15094
	10.0	15377



PEOPLE / ENVIRONMENT / MACHINERY // TRIPLE PROTECTION

PIPES AND PIPE CONNECTION COMPONENTS

TBH offers a wide range of pipes and pipe connection components for a variety of different applications. System Safe is primarily used here due to its easy mounting and type-approval for leak tightness class A, B, C, D in accordance with DIN EN 12237 SITAC no. 1358/88. The system is based on factory-assembled double-lip seals made of age-resistant EPDM rubber. The robust seal, on which temperature fluctuations have minimal impact, creates an airtight connection.

Various adapters and connection parts from other systems are available in addition to System Safe. These serve to expand the wide range of products on offer.

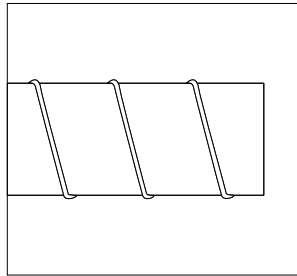

FOLDED SPIRAL-SEAM PIPE

Length: 3 metres

DN (mm)	Item No.
63	10570
80	10573
100	10575
125	10579
160	10587
180	10591
200	10595
224	10599
250	10603

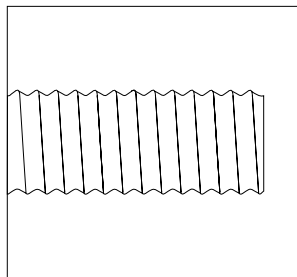

AluFlex pipe

Length: 1.25 metres

DN (mm)	Item No.
80	11064
100	11124
125	10808
160	10878
200	11024
250	11056

PIPES AND PIPE CONNECTION COMPONENTS

THE SYSTEM:

- easy to fit components
- guaranteed leak tightness

- parts can be easily inserted into each other and turned without leak tightness being affected
- suitable for temperature range -30°C to +100°C

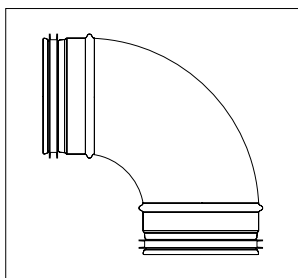
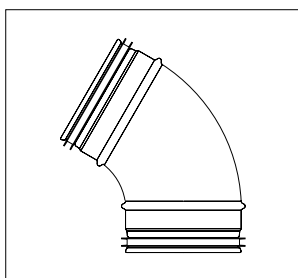
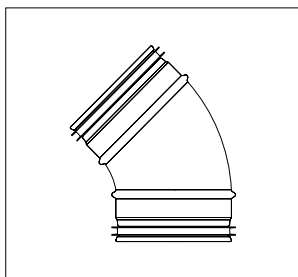
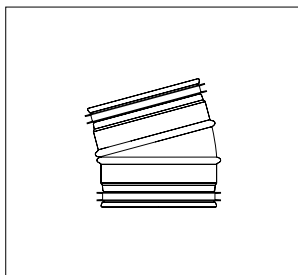

PIPE ELBOW 15°

DN (mm)	Item No.
63	10464
80	10467
100	10438
125	10442
160	10448
180	10452
200	10458
224	10461
250	10463

PIPE ELBOW 45°

DN (mm)	Item No.
63	10466
80	10436
100	10441
125	10445
160	10453
180	10456
200	10462
224	10468
250	10471

PIPE ELBOW 60°

DN (mm)	Item No.
63	10474
80	10477
100	10481
125	10484
160	10491
180	10494
200	10498
224	10472
250	10475

PIPE ELBOW 90°

DN (mm)	Item No.
63	10478
80	10483
100	10486
125	10489
160	10497
180	10470
200	10473
224	10476
250	10479

PIPES AND PIPE CONNECTION COMPONENTS

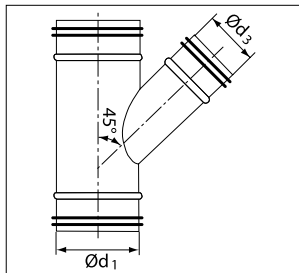

JUNCTION 45°

$\varnothing d_1$ (mm)	$\varnothing d_3$ (mm)	Item No.
63	63	10640
80	63	10617
	80	10618
100	63	10624
	80	10627
	100	10641
125	63	10631
	80	10634
	100	10622
	125	10637
160	63	10662
	80	10666
	100	10670
	125	10674
	160	10647
180	63	10717
	80	10651
	100	10655
	125	10659
	160	10668
200	63	10714
	80	10675
	100	10644
	125	10649
	160	10656
	180	10660
250	200	10655
	63	10766
	80	10669
	100	10671
	125	10676
	160	10648
	180	10653
	200	10657
	224	10764
250	10661	

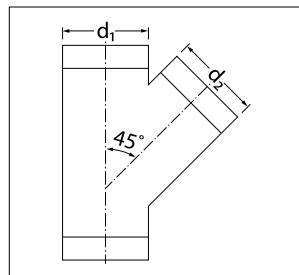

JUNCTION 45°

$\varnothing d_1$ (mm)	$\varnothing d_2$ (mm)	Item No.
50	50	10451

PIPES AND PIPE CONNECTION COMPONENTS

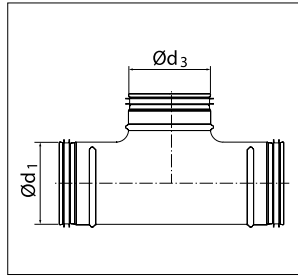

JUNCTION 90°

Ø d ₁ (mm)	Ø d ₃ (mm)	Item No.
63	63	10663
	80	10667
80	63	10672
	80	10679
	100	10683
100	100	10687
	63	10691
	80	10695
	100	10699
125	125	10703
	63	10693
	80	10698
	100	10702
	125	10706
160	160	10818
	63	10677
	80	10682
	100	10686
	125	10690
180	160	10697
	63	10705
	80	10709
	100	10678
	125	10680
200	160	10688
	180	10692
	200	10696
	63	10700
	80	10704
	100	10708
250	125	10715
	160	10758
	180	10712
	200	10722
	224	10757
	250	10760

PIPES AND PIPE CONNECTION COMPONENTS

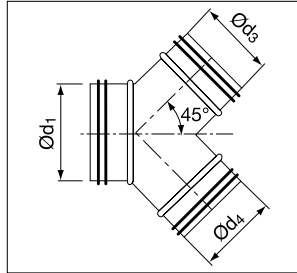

Y-SECTION

Ø d ₁ (mm)	Ø d ₃ (mm)	Ø d ₄ (mm)	Item No.
63	63	63	12160
80	63	63	12116
	80	80	13096
100	63	63	11652
	80	80	12119
	100	100	13607
125	80	80	11700
	100	100	12977
	125	125	15508
160	80	80	11333
	100	100	11365
	125	125	13390
	160	160	12121
200	125	125	10807
	160	160	13530
250	Upon request		

PIPES AND PIPE CONNECTION COMPONENTS

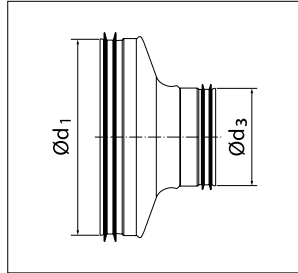

REDUCTION

Ø d ₁ (mm)	Ø d ₃ (mm)	Item No.
80	63	10607
100	63	10611
	80	10614
125	63	10585
	80	10589
	100	10592
160	63	10613
	80	10581
	100	10586
	125	10590
180	63	10596
	80	10602
	100	10604
	125	10608
	160	10582
200	63	10584
	80	10588
	100	10594
	125	10597
	160	10605
	180	10609
224	63	10616
	80	10619
	100	10621
	125	10625
	160	10630
	180	10633
	200	10636
250	63	10639
	80	10615
	100	10620
	125	10623
	160	10629
	180	10632
	200	10635
	224	10638

PIPES AND PIPE CONNECTION COMPONENTS

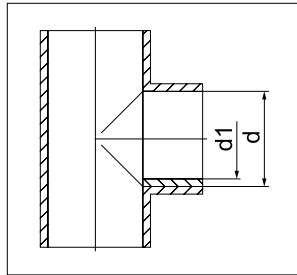

SPECIAL REDUCTION

for insertion into the cover of the system

Ø d (mm)	Ø d ₁ (mm)	Item No.
50 (external)	32 (external)	11216

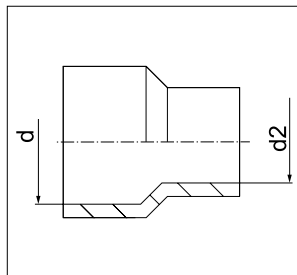

SPECIAL REDUCTION

for adapting Lindab System 63 to hose DN 50

Ø d (mm)	Ø d ₂ (mm)	Item No.
63 (internal)	50 (internal)	14619
75 (external)	63 (external)	

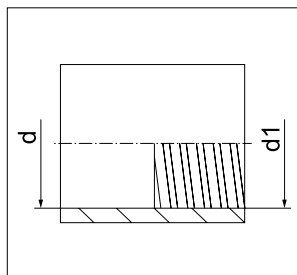

SPECIAL REDUCTION

for adapting hose DN 44 to Alsident System 50

Ø d (mm)	Ø d ₁ (mm)	Item No.
50	50	15639

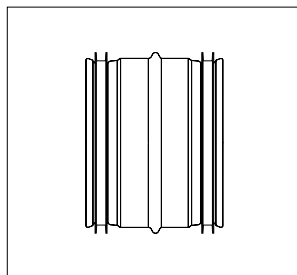

NIPPLE FOR PIPES

DN (mm)	Item No.
63	10482
80	10487
100	10490
125	10493
160	10469
180	10480
200	10485
224	10495
250	10508

PIPES AND PIPE CONNECTION COMPONENTS

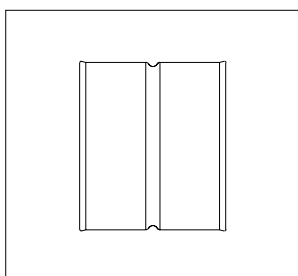

SOCKET FOR MOULDED PARTS

DN (mm)	Item No.
63	10512
80	10517
100	10520
125	10524
160	10499
180	10503
200	10506
224	10510
250	10515

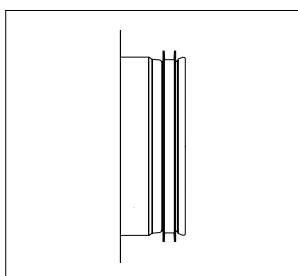

FLANGED COLLAR WITH FLAT FLANGE

DN (mm)	Item No.
80	10563
100	10566
125	10569
160	10577
180	10578
200	10094
224	10564
250	10567

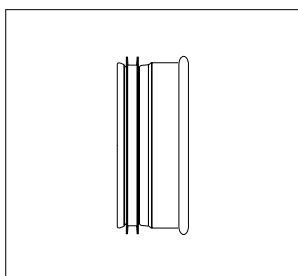

END COVER FOR PIPES

DN (mm)	Item No.
63	10519
80	10523
100	10527
125	10530
160	10504
180	10507
200	10511
224	10514
250	10516

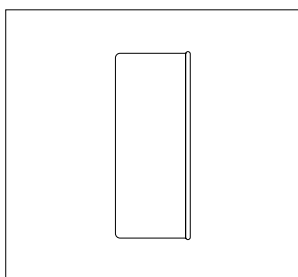

END COVER FOR MOULDED PARTS

DN (mm)	Item No.
63	10521
80	10526
100	10529
125	10500
160	10505
180	10509
200	10513
224	10518
250	10522

PIPES AND PIPE CONNECTION COMPONENTS

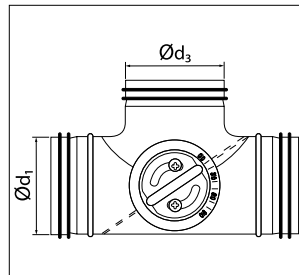

BYPASS DAMPER

Bypass dampers replace a costly construction with two conventional flaps

Ø d ₁ (mm) / Ø d ₃ (mm)	Item No.
80	11618
100	10557
125	10086
160	10089
200	10533

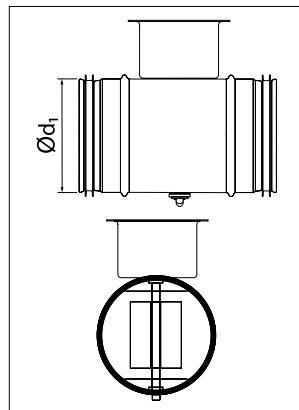

SHUT-OFF FLAP (airtight)

Shut-off flap seals tightly to completely block the air flow

Ø d ₁ (mm)	Item No.
80	11146
100	10540
125	10544
160	10552
180	10556
200	10088

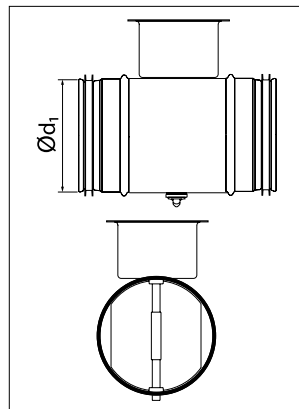

REGULATING FLAP

Regulating flaps are used to throttle the unit in order to obtain the desired flow rate

Ø d ₁ (mm)	Item No.
63	10562
80	10565
100	10574
125	10560
160	10571
180	10576
200	10580
224	10092
250	10095

ACCESSORIES PIPES AND PIPE CONNECTION COMPONENTS

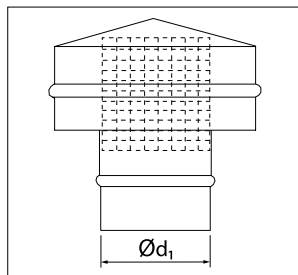

ROOF HOOD

Ø d₁ (mm)	Item No.
63	11611
80	11614
100	10525
125	10532
160	10539
180	10543
200	10546

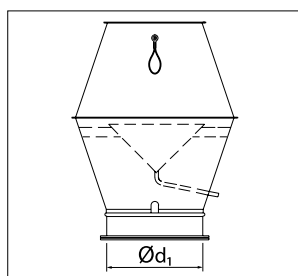

DEFLECTOR HOOD

Ø d₁ (mm)	Item No.
63	Upon request
80	Upon request
100	10087
125	10090
160	10538
180	10542
200	10547

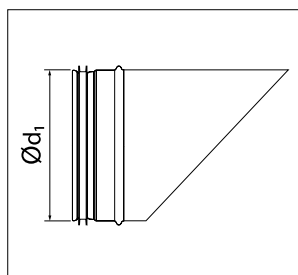

EXHAUST VENT FOR WALL WITH PROTECTIVE SCREEN

Ø d₁ (mm)	Item No.
63	10558
80	10986
100	10091
125	10531
160	10541
180	10545
200	10548
224	11479

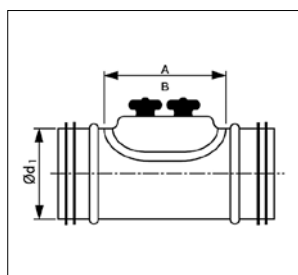

CLEANING PIECE

allows easy access to the pipeline for cleaning

Ø d₁ (mm)	Cover size A x B (mm)	Item No.
125	180x80	15522
160	180x80	15523
200	200x100	15524
250	200x100	15525

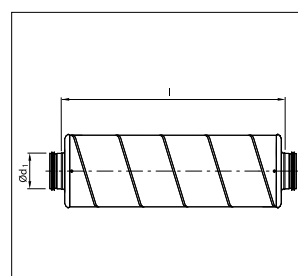

SILENCER

Ø d₁ (mm)	Length (mm)	Item No.
125	900	10852
160	900	10859
200	900	10886
250	900	10397

Further diameters and lengths upon request. Please contact the TBH sales team.

Slide valves are, for example, used if compressed air is to be prevented from being blown back into the pipeline (cleaning). This prevents deposits in the hose from getting back into the processing unit or prevents processing from being interrupted. The slide valves are available as either pneumatically actuated (compressed air connection, triggering by 24 V or 230 V) or hand-actuated.

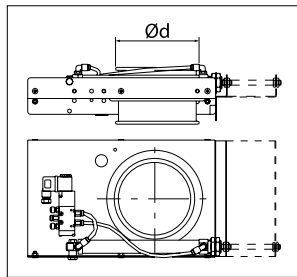

SLIDE VALVES

pneumatically actuated

Ød (mm)	24 V DC Item No.	230V AC Item No.
80	15286	14938
100	15287	15776
125	15288	14900
160	15289	14901
200	15290	14899
250	15291	Upon request

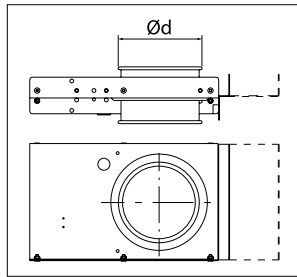

SLIDE VALVES

actuated by hand

Ød (mm)	Item No.
80	15509
100	15517
125	15518
160	15519
200	15520
250	15521



Similar to image

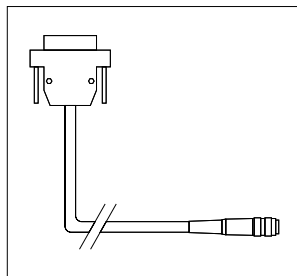

CONNECTION LINE

for stop valve, pneumatically actuated, for connecting to the cleaning control system (FP/FPV)

Length (m)	Voltage	Item No.
3	24 V DC	15337

Connection line with Sub-D9 plug for connecting to the cleaning control system (FP/FPV)



Similar to image

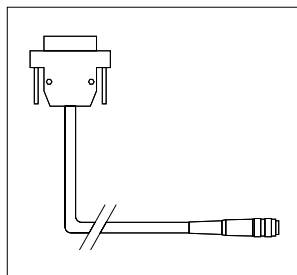

CONNECTION LINE

for stop valve, pneumatically actuated, for connecting to a customer-specific control system

Length (m)	Voltage	Item No.
3	24 V DC / 230 V AC	15775

Connection line with open ends

PRE-SEPARATOR

Spark pre-separators are connected upstream in order to intercept sparks and glowing parts from the process of an extraction and filtration unit. They are used with different principles.

MATERIAL:

Housing: Steel (powder-coated)

Colour: RAL 7035

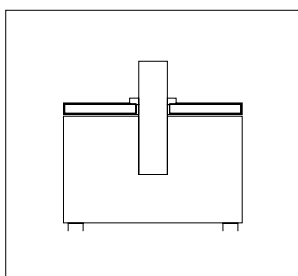

SPARK PRE-SEPARATORS FA 10

Filtration module with a connection for a suction arm

Use: LN230, GL230

TYPE	HxWxD (mm)	Suction arm	Item No.
FA 10	230x350x350	50	13947
		63	13950
		75	13923

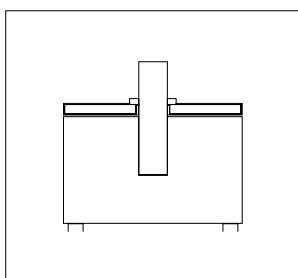

SPARK PRE-SEPARATORS FA 20

Filtration module with a connection for a suction arm

Use: LN260/265, GL265/400

TYPE	HxWxD (mm)	Suction arm	Item No.
FA 20	265x350x655	63	13952
		75	13914

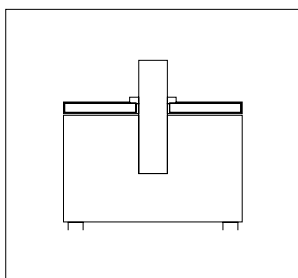

SPARK PRE-SEPARATORS FA 10

Filtration module with a connection for a suction hose

Use: LN230, GL230

TYPE	HxWxD (mm)	Suction arm	Item No.
FA 10	230x350x350	50	13946
		63	15542
		75	15543

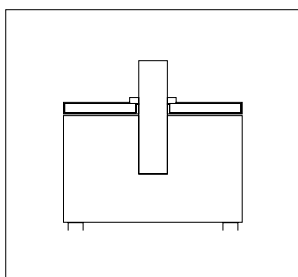

SPARK PRE-SEPARATORS FA 20

Filtration module with a connection for a suction hose

Use: LN260/265, GL265/400

TYPE	HxWxD (mm)	Suction arm	Item No.
FA 20	265x350x655	63	15544
		75	15545

Spark separators of type FA10 and FA20 are built into an extraction unit as a filtration module. They operate purely mechanically by means of air deflection through an aluminium mesh. They can be easily integrated into the existing system and do not require any additional floor space.

The WBA 30 is a so-called water quenching pre-separator. It is connected as an individual module upstream of the extraction and filtration unit. With regard to the WBA 30, the air is fed through a water bath in which any possible sparks are extinguished.

MATERIAL:

Housing: Steel (powder-coated)

Colour: RAL 7035

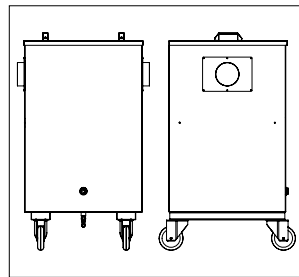

WBA 30 MODULE

Use: LN230, GL230, LN260/265, GL265/400

TYPE	HxWxD (mm)	DN (mm)	Item No.
WBA 30	1120x620x615	50 - 160	13263

Cyclone separators are used as pre-separators in processes with a large concentration of dust or as spark pre-separators in grinding/laser processes. They are connected upstream of an appropriately configured extraction and filtration unit. In the separator, the air is sent into rotating motion, which presses the particles out of the air flow and thus separates them. The separation level of a cyclone separator is in this instance approximately 80% (10µm).

MATERIAL:

Housing: Steel (powder-coated)

Colour: RAL 7035

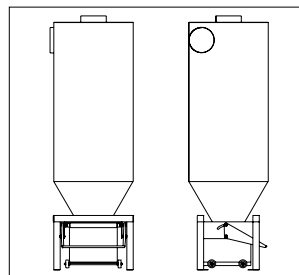

CYCLONE SEPARATOR

Dust collection container with Quicklock System

TYPE	Height (mm)	Item No.
CN 500	1427	11007
CN 1000	1491	11005
CN 1500	1600	11008
CN 2000	1745	11011
CN 3000	1710	11013
CN 4000	1880	11615

Technical specifications	Unit	CN 500	CN 1000	CN 1500	CN 2000	CN 3000	CN 4000
Air flow rate max.	m³/h	500	800	1400	2100	3500	5100
Pressure drop	Pa	1100	1100	1100	1100	1100	1100
Diameter	mm	300	375	500	600	750	950
Connection ports	mm	100	125	160	200	250	315
Dust collector	L	17	17	17	38	38	38
Standing surface	mm	390 x 500	390 x 500	390 x 500	600 x 600	750 x 750	950 x 950

FANS

A number of fans can be found in the TBH accessories range. The fans serve to increase extraction power and can, for example, be connected to a filtration cartridge pre-separator.

In general, you should take the following points into consideration when choosing a fan:

- Pressure drop by means of attached extraction lines (depending on cross-section and length)
- Pressure drop by means of an attached filtration unit (e.g. FPV202)
- Requisite extraction power
- Requisite air speed / air flow rate at the point of extraction and in the lines

Please contact your TBH sales team regarding the design of your specific application.

A selection of fans with different characteristics can be found in the following section. Further fans are available upon request.

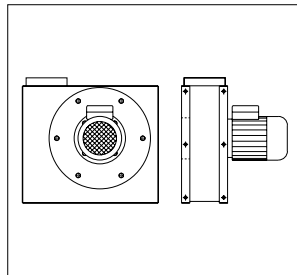

TYPE VT (for smaller extraction power)

suitable for transportation of contaminated air and shavings

FAN TYPE	HxWxD (mm)	Item No.
VT 500	358x409x391	11061
VT 1000	372x531x488	12057
VT 2000	412x531x488	11058

Technical specifications	Unit	VT 500	VT 1000	VT 2000
Air flow rate max.	m ³ /h	650	1150	1600
Max. static pressure	Pa	1300	1600	1600
Operating point	m ³ /h@ / Pa	500 / 800	900 / 1000	1500 / 1000
Voltage	(V)	400	400	400
Power	(kW)	0.37	0.75	1.1
Starting current	(A)	4	9.5	14.9
Intake area	-	100	125	160
Discharge area	-	100	160	160
Weight	Kg	12	19	20

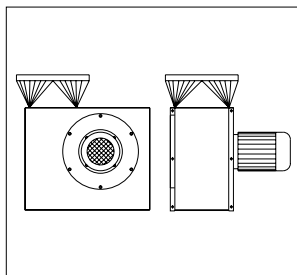

TYPE VH (for mid-range extraction power)

suitable for transportation of contaminated air and shavings

FAN TYPE	HxWxD (mm)	Item No.
VH 900	392x613x633	11586
VH 1800	428x613x633	11588
VH 2700	435x613x633	11046

Technical specifications	Unit	VH 900	VH 1800	VH 2700
Air flow rate max.	m ³ /h	1600	2500	4500
Max. static pressure	Pa	2000	2480	2550
Operating point	m ³ /h@ / Pa	1200 / 1000	2500 / 1000	4000 / 1000
Voltage	(V)	400	400	400
Power	(kW)	0.75	1.5	2.2
Starting current	(A)	9.5	25.0	34.3
Intake area	-	125	160	200
Discharge area	-	125	160	200
Weight	Kg	25	30	33

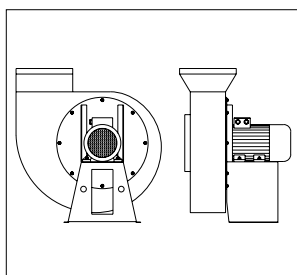

TYPE RV (for great extraction power)

suitable for transportation of purified air

FAN TYPE	HxWxD (mm)	Item No.
RV 45-C2	737x837x1012	15778
RV 50-C2	870x859x1017	15779

Additional fans with > 6000 m³/h are available upon request. Please contact the TBH sales team in this regard

Technical specifications	Unit	RV 45-C2	RV 50-C2
Air flow rate max.	m ³ /h	5400	11500
Max. static pressure	Pa	3600	3800
Operating point	m ³ /h@ / Pa	5000 / 3400	6500 / 3400
Voltage	(V)	400	400
Power	(kW)	7.5	11
Starting current	(A)	112.2	156
Intake area	-	315	400
Discharge area	-	315	400
Weight	Kg	125	145

FANS

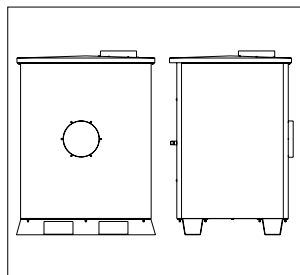

SILENCER HOODS

FAN TYPE	HxWxD (mm)	Item No.
VT 500	747x756x699	11400
VT 1000	747x756x699	12061
VT 2000	747x756x699	11484
VH 900	879x838x744	11589
VH 1800	879x838x744	15934
VH 2700	879x838x744	15935
RV 35/3	1284x1020x897	11567
RV 45	1322x1142x1147	15936
RV 50	1322x1142x1147	15937

Technical specifications	Unit	VT 500	VT 1000	VT 2000	VH 900	VH 1800	VH 2700	RV 35/3	RV 45	RV 50
Intake area	-	100	125	160	125	160	200	250	400	400
Discharge area	-	100	160	160	125	160	200	250	400	400
Weight*	Kg	57	66	67	94	101	104	245	310	324

* includes fan



MOTOR OVERLOAD SWITCH

actuated by hand

FAN TYPE	Item No.
VT 500	15927
VT 1000, VH 900	15928
VT 2000, VH 1800	15929
VH 2700	15930
RV 35/3, RV 45*	15931

* only operate in connection with a star-delta control system. Check use.



MOTOR STARTER - STAR-DELTA START-UP

actuated by hand, automatic switching between star-delta

FAN TYPE	Item No.
RV 35/3, RV 45, RV 50	15932

Motor starter with manual switching between star and delta connection

EXTRACTION BENCH, EXTRACTION PANEL

MATERIAL: Steel (powder-coated) in RAL 7035

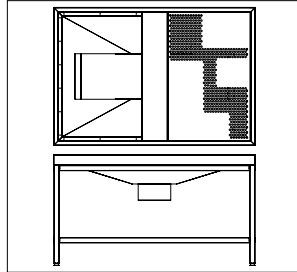

EXTRACTION BENCH

with two removable grids

Extraction connection	HxWxD (mm)	Item No.
250	850x1550x1060	13899

Extraction bench for cleaning parts with solvents etc. Downward direction of extraction. Please contact the TBH sales team regarding the design of a suitable extraction and filtration unit for the application.

MATERIAL: Steel (powder-coated) in RAL 7035

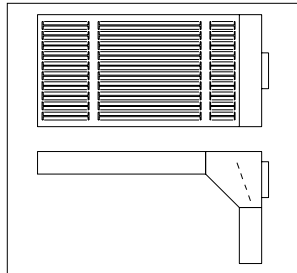

EXTRACTION PANEL PU (for grinding work)

suitable for extraction when grinding with angle grinders or random orbital sanders

Use: excellent for collecting flying sparks

Extraction connection	HxWxD (mm)	Item No.
160	500x1000x500	15938
160	500x1000x1000	15939

Technical specifications	Unit	Type 1	Type 2
Differential pressure drop	Pa	900	900
Weight	Kg	19	39
Minimum air flow rate	m ³ /h	1350	1800

MATERIAL: Steel (powder-coated) in RAL 7035

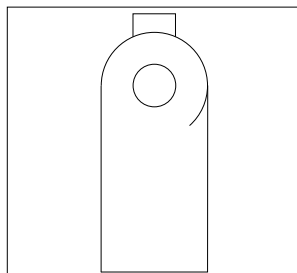

EXTRACTION HOOD (extraction panel for grinding work)

suitable for extraction of vapours, gases (not ATEX) and light dusts

TYPE	Extraction connection	HxWxD (mm)	Item No.
GT 500B	125	680x500x315	15940
GT 1000B	125	680x1000x315	15941
GT 1500B	160	900x1500x400	15942

Technical specifications	Unit	GT 500B	GT 1000B	GT 1500B
Minimum air flow	m ³ /h	300	500	1000
Differential pressure drop	Pa	300	300	300
Weight	Kg	18	28	44

REMOTE CONTROLS



CABLE REMOTE CONTROL

Use: for connecting to the interface of an extraction and filtration unit from the LN Series, FP Series, GL Series

Comprised of: Remote control (including cable)

Cable length	Item No.
7 metres	13771

The device has the following functions:

- Display 'Filter full'
- Switching between Run/Stand-by
- Control of rotation speed
- Original state of the unit: Stand-by mode

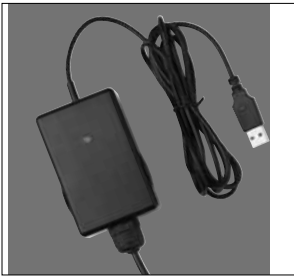

USB REMOTE CONTROL

Use: Extraction and filtration unit from the LN Series, FP Series, GL Series

Comprised of: Remote control (including cable), control program*

Cable length	Item No.
7 metres	13830

* compatible with Microsoft Windows. No additional drivers are required.

The device has the following functions:

- Switching between Run/Stand-by
- Original state of the unit: Stand-by mode



ELECTRICAL FOOT SWITCH

Use: for connecting to the interface of an extraction and filtration unit from the BF Series

Comprised of: Foot switch (including cable)

Cable length	Item No.
2 metres	13772

The device has the following functions:

- Switching between Run/Stand-by
- Original state of the unit: Stand-by mode



FOOT SWITCH

Use: for connecting to the interface of an extraction and filtration unit of type LN 100

Comprised of: Foot switch (including cable)

Cable length	Item No.
3 metres	11442

The device has the following functions:

- Switching between Run/Stand-by



INTERFACE ADAPTERS

Control cable TBH

Designation	Use	Cable length	Item No.
Trotec	LN 200 Series, FP 200 Series	4 m	14032
Roland Dental Mill DWX-50	LN 200 Series, FP 200 Series, BF Series	1.8 m	15908
VHF K-model, S-model	LN 200 Series, FP 200 Series, BF Series	2.5 m	15923



DUST BAG SET

Dust bag for low contamination disposal of purified filtrates

Designation	Use	Item No.
Pack of 10 dust bags	FP150	15711
Pack of 10 dust bags	FP211, FP213	14367



BERG Technics

EXHAUST- AND FILTRATION TECHNOLOGY

GERMANY

www.bergtechnics.ru

info@bergtechnics.ru

